



# LIGO MAGAZINE

issue 11 9/2017

## 02: Third Detection!

10:11:58.6 UTC, 4 January 2017



### 50 Years of Pulsars: Jocelyn Bell Burnell

An interview p.6

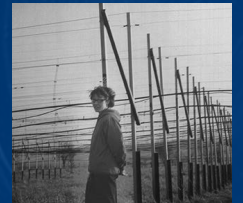

### The Search for Continuous Waves

To name a neutron star p.10

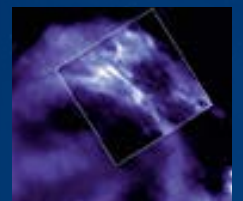

... and in 1989: The first joint interferometric observing run p.26

## Before the Merger: Spiraling Black Holes

Front cover image: Artist's conception shows two merging black holes similar to those detected by LIGO. The black holes are spinning in a non-aligned fashion, which means they have different orientations relative to the overall orbital motion of the pair. LIGO found a hint of this phenomenon in at least one black hole of the GW170104 system.

Image: LIGO/Caltech/MIT/Sonoma State (Aurore Simonnet)

### Image credits

**Front cover main image** – Credit: LIGO/Caltech/MIT/Sonoma State (Aurore Simonnet)

**Front cover inset LISA** – Courtesy of LISA Consortium/Simon Barke

**Front cover inset of Jocelyn Bell Burnell and the 4 acre telescope** c 1967 courtesy Jocelyn Bell Burnell.

**Front cover inset of the supernova remnant G347.3-0.5** – Credit: Chandra: NASA/CXC/SAO/P.Slane et al.; XMM-Newton:ESA/RIKEN/J.Hiraga et al.

p. 3 Comic strip by Nutsinee Kijbunchoo

p. 4-5 Photos by Matt Gush, Bryce Vickmark and Josh Meister

p. 6 Jocelyn Bell Burnell and the 4 acre telescope courtesy Jocelyn Bell Burnell. Paper chart analysis courtesy Robin Scagell

p. 8 Pulsar chart recordings courtesy Mullard Radio Astronomy Observatory

p. 10 Crab image X-ray: NASA/CXC/SAO; Optical: NASA/STScI; Infrared: NASA/JPL/Caltech; Radio: NSF/NRAO/VLA; Ultraviolet: ESA/XMM-Newton

p. 11 Circinus X-1 image X-ray: NASA/CXC/Univ. of Wisconsin-Madison/S.Heinz et al; Optical: DSS; Radio: CSIRO/ATNF/ATCA.

G347.3-0.5 image Chandra: NASA/CXC/SAO/P.Slane et al.; XMM-Newton: ESA/RIKEN/J.Hiraga et al.

p. 12 Pia Astone image courtesy @IREISGufficiale, Istituto Nazionale Tumori Regina Elena e Istituto Dermatologico San Gallicano (IRCCS)

p. 14 Spin disk plot LSC/Katerina Chatziioannou

p. 15 Lorentz invariance violations LSC/Tyson Littenberg/Anuradha Samajdar. Sky localization LIGO/Caltech/MIT/Leo Singer (Milky Way image: Axel Mellinger)

p. 16 LHC Tunnel CERN/Maximilien Brice

p. 17 ALICE experiment CERN/A. Saba

p. 20 Event display courtesy ATLAS

p. 21,23 CERN

p. 22 CERN/Maximilien Brice/Laurent Egli

p. 18-19 Graphic story by Nutsinee Kijbunchoo

p. 24 Courtesy of ESA–C.Carreau

p. 25 Image courtesy of AEI/MM/exozet; GW simulation: NASA/C. Henze

p. 26 Input mirror courtesy MPQ, Garching; inside the vertex chamber courtesy D. Dewey

p. 27 Figure 1: David Robertson

p. 28 MPQ, Garching

p. 29 Figure 3: David Robertson

p. 30 Courtesy of American Physical Society

p. 31 NASA Goddard/David Friedlander

- 4 Welcome
- 5 LIGO Scientific Collaboration News – Foreword
- 6 50 years of pulsars - An interview with Jocelyn Bell-Burnell
- 10 The search for Continuous Waves
- 13 Gravitational waves from 3 billion light years away
- 16 Building big-physics experiments: the CERN model
- 18 An Operator's story
- 24 Goodbye LPF! Hello LISA!
- 26 The first joint interferometric observing run
- 30 Remembering Ron Dever
- 31 Remembering Neil Gehrels
- 32 Comment: Searching for a faculty job
- 33 We hear that ... – Career Updates, Awards and More
- 35 The LIGO Magazine #11 – Masthead
- 36 How did you spend your Breakthrough Prize money?

## Antimatter

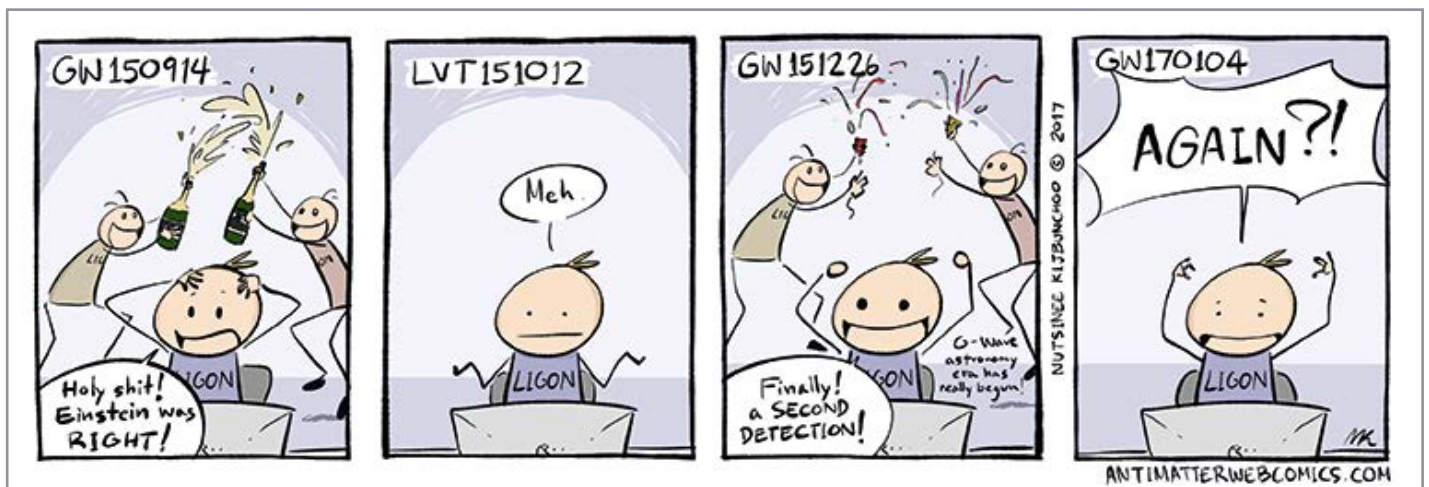



# Welcome to the LIGO Magazine Issue #11!



*Jocelyn Read*

I write this in the final month of Advanced LIGO's second observing run. The LIGO and Virgo collaborations have announced our third confirmed gravitational-wave detection this summer ("Gravitational waves from three billion light-years away"), and Advanced Virgo has recently joined the LIGO detectors for international observations. In this issue, we see the story of Nutsinee Kijbunchoo's experience as an Advanced LIGO "operator," monitoring and running the observatory on-site. We also look back to 1989, when the first international collaboration of gravitational-wave interferometers in Glasgow and Garching jointly collected astrophysical data in "The first joint interferometric observing run." This history emphasizes that gravitational-wave science has always been an international effort, but we can still learn from the experiences of other multi-national collaborations; in this issue, we bring you Matthew Chalmers' perspective on "Building big-physics experiments: the CERN model."

This summer also marked the 50th anniversary of the first detection of pulsars, spinning neutron stars sending out steady radio blips that later provided the first measurement of gravitational-wave effects. In this issue, Hannah Middleton interviews Jocelyn Bell-Burnell about her "50 years of pulsars," and we also hear from the LIGO and Virgo collaborations' own neutron-star hunters in "The search for continuous waves."

To round out our eleventh issue of the LIGO Magazine, we share recent news from our space-based detector colleagues. We also welcome our new spokesperson, David Shoemaker, and assistant spokesperson Laura Cadonati, who write their first installment of LIGO news this issue.

It takes the joint work of many volunteers to write, illustrate, and edit each issue of the LIGO Magazine, and I appreciate the time that each of them has contributed to this issue and hope they find the results as rewarding as I do. If you have any ideas, suggestions, or stories, please send us an email at [magazine@ligo.org](mailto:magazine@ligo.org).

*Jocelyn Read for the Editors*





# LIGO Scientific Collaboration News

**W**e took over from the very successful leadership of Gaby González as Spokesperson and Marco Cavaglià as Assistant Spokesperson in March 2017, and have been learning on the job since that time. It has been an eventful six months!

The O2 observing run has been underway since November 2016. The Hanford instrument has been observing with roughly the same reach as in the O1 run, at 60-70 Mpc reach for binary neutron stars. The Livingston instrument sensitivity has been as high as 100 Mpc for binary neutron stars, and the uptime has allowed a significant body of data to be collected. While a thorough search of the entire run, for all anticipated signal types, is yet to be completed, the data has already borne fruit: we brought to publication the discovery of our 3rd binary black hole GW170104. With this, we have stepped squarely into the epoch of gravitational-wave astronomy, with new insights into both astrophysical inferences on rates and mass distributions of stellar-mass black holes as well as more stringent tests of Einstein's general relativity.

As we write, another significant step forward in our field is being made: the Advanced Virgo Detector has joined the O2 run for the final month. While initially at a lower sensitivity than the LIGO instruments, the addition of a third interferometer has the promise of giving better location information for sources which can be passed on to electromagnetic-domain observing partners, along with better uptime and the possibility of measuring the polar-

ization state of gravitational waves. We also thank Fulvio Ricci for his leadership of Virgo, and welcome Jo van den Brand, the new Virgo Spokesperson.

Last year, Gaby put into place a study of the evolution of the collaboration to adapt to changes indicated by its size, scope of interests, and above all its transition to the post-first-detection era. We are working to interpret the recommendations of the reorganization study, and to put into place changes that we believe will help it succeed in making the best use of the science and the human resources of the collaboration. The LSC Council will work through the feedback and choose the right path at the CERN LVC meeting.

The LIGO instruments, after the end of the O2 run, will undergo significant work to bring the sensitivity into the planned range for O3. This will involve replacing some of the test mass optics, changes in the lasers, introduction of squeezing to the Livingston instrument, and a number of changes in-vacuum to reduce scattered light. The changes are expected to take about one year, during which the rest of the collaboration will be busy with improvements to the pipelines, adding more automation to some data quality assessments and to the electromagnetic follow-up system, and supporting commissioning remotely. The start of O3, planned for the Fall of 2018, should provide another qualitative shift in the astrophysics we can recover and the way the Virgo and LIGO collaborations work together to reap the significant new science to come.



David Shoemaker  
LSC Spokesperson



Laura Cadonati  
LSC Deputy Spokesperson



*David Shoemaker and Laura Cadonati*

## 50 years of pulsars:

# An interview with Jocelyn Bell Burnell

**P**rofessor Dame Jocelyn Bell Burnell discovered the first pulsar signal in 1967 during her PhD in Cambridge. Since then, she has worked in many areas of astrophysics (right from radio to gamma-ray), held positions on more research council boards, committees and panels than she cares to remember, and been awarded numerous medals, prizes, fellowships, and honorary doctorates. She is currently the president of the Royal Society of Edinburgh. She is active in encouraging women in science and won the 2010 Faraday Medal for science communication. In her spare time she walks, gardens, listens to choral music, is active in the Religious Society of Friends (Quakers) and has co-edited an anthology of poetry with an astronomical theme – ‘Dark Matter; Poems of Space’.



*The charts were analysed by hand:  
Jocelyn Bell Burnell working on a pulsar chart.*

Hannah Middleton: Pulsars are stars, but they are not like normal stars. What are they like and where can I find one?

**Jocelyn Bell Burnell:** Massive stars end their lives with a catastrophic explosion (a supernova) in which 90 - 95% of the star is ejected. The core collapses in the explo-

sion and becomes one of these neutron stars (i.e. neutron-rich stars, not pure-neutron stars). Pulsars are neutron stars that for some reason also have a large magnetic field that spins with the star. Typically they are about 10 miles across (10 km radius), have the same mass as the Sun and so are phenomenally dense. Their strong surface gravity bends light etc around the surface, redshifts the light (little green men would appear as little red men!) and makes clocks go at half the rate they do here on earth. There is also a strong gradient of gravity which tidally disrupts bodies that come too close! Something free-falling onto a pulsar/neutron star hits the surface travelling at half the speed of light.

Most known pulsars have been found through their radio emission, and they are not very strong so a large radio telescope is needed. They cannot be seen in the normal meaning of the word. Probably the most famous one is in the centre of the Crab Nebula.



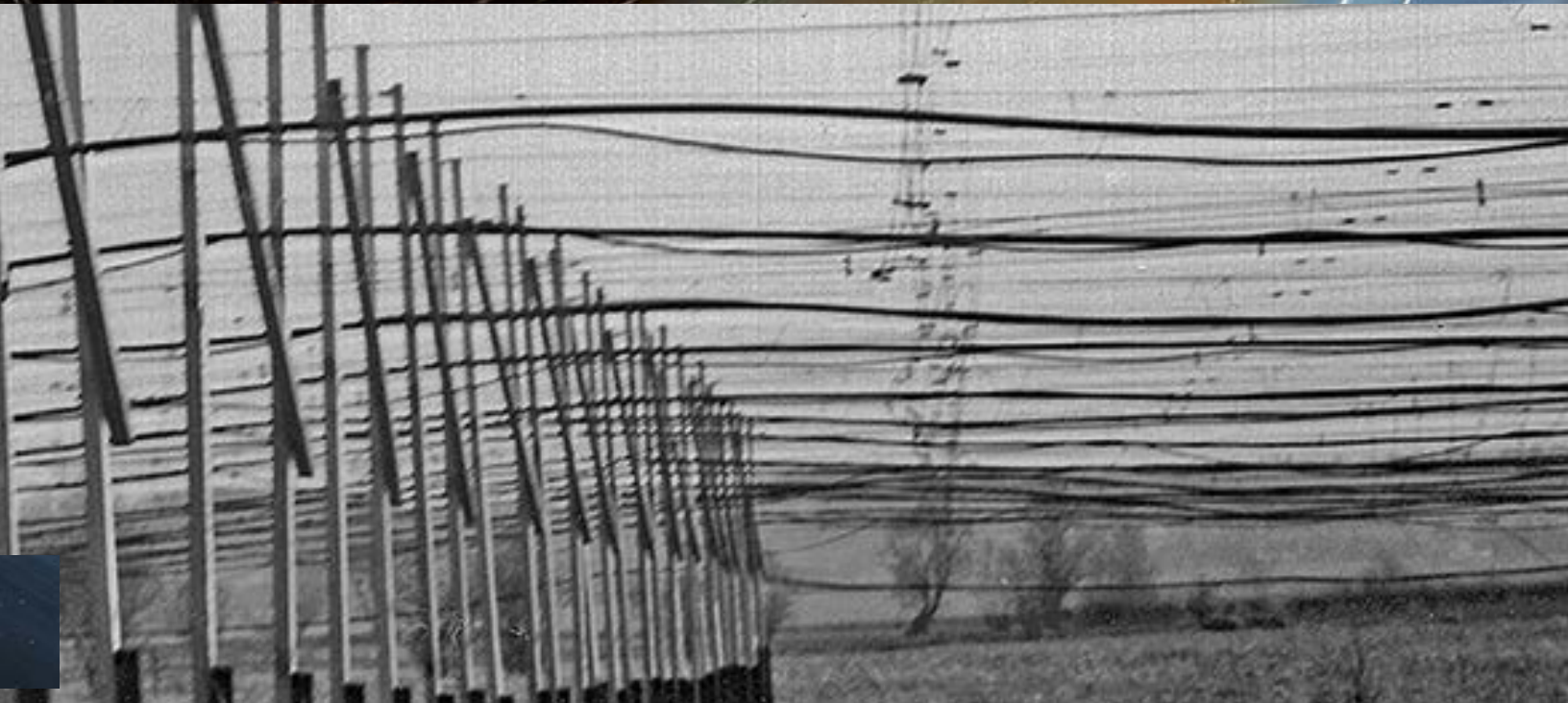

▲  
*Jocelyn Bell Burnell and the 4 acre telescope c 1967.*

Hannah: It was during your PhD at Cambridge that you discovered the first pulsar, but you were actually searching for quasars?

**Jocelyn:** Yes, the story starts in 1965. Just two years earlier it had been recognised that optical spectra of quasars showed enormous redshifts, yet they were amongst the most luminous objects in the radio sky. The large redshift only increased the puzzlement about what these objects were.

Not many quasars were known and it was clearly important to increase the sample size. It was known that at low radio frequencies compact objects rapidly change in brightness (or “scintillated”). This is caused by the radio waves propagating through an inhomogeneous, moving medium; in this case the solar wind. Fluctuations in electron density diffract the radio waves, and because the fluctuations are moving across the line of sight the intensity of the source changes. Large angular diameter objects (such as radio galaxies) are sufficiently broad that they are seen through

several fluctuations, and do not suffer the same changes in intensity.

So this technique is a neat way of identifying quasars through their interplanetary scintillation. When I arrived in Cambridge, Tony Hewish had just got a grant to build a radio telescope to search for more quasars using this technique. Since a short integration time had to be used, to keep a good signal-to-noise ratio a large collecting area was needed.

Hannah: You were involved in both the construction of the instrument as well as analysing long stretches of data by hand. Was it usual to be involved in such different aspects of a project?

**Jocelyn:** There was a lot of hammering posts into the ground (some summer students did a lot of that); there was a lot of cutting and brazing together of pieces of copper wire to make the antennae; more wires were strung to make a reflector screen and more to make catenaries to carry the cables. There were about six of us who spent two years building the telescope, and sev-

eral more guys in the electronics workshop who built the receivers. I was responsible for the cables, balance-to-unbalance transformers and the connectors.

It was indeed normal for PhD students to be involved in the construction of radio telescopes - indeed we were presented with a set of tools (screwdriver, pliers, wire cutters, etc!) as we joined! When the construction was complete, the rest of the construction crew melted away to other projects and I was left to operate the telescope (with supervision from Tony Hewish, my PhD supervisor).

From the data analysis point of view, there was very little computer power available - very few projects had time on the Cambridge University ‘main frame’ (which had less memory than a single laptop today!). We did not have access to it. The data from our telescope came out on long rolls of paper chart, and it was my responsibility to analyse these charts. By the end of 6 months’ observing I had 5.3 km of chart! The telescope had relatively few problems,



# 1967: The story begins

working the first time it was switched on. But like every piece of equipment it had its foibles and I had to learn what a quasar looked like on the charts, what artificial interference looked like, and sort out what several other 'features' were.

A personal diversion at this point.... I had started life in Northern Ireland, been at school in the north of England and done a physics degree in Glasgow (and had Ron Drever as a tutor!). I was definitely from the rural (backward?) fringes of the country, and almost by accident found myself in Cambridge, this great southern mecca of learning. Everyone there seemed very bright (some were very keen to let you know it too!). I can now see that I suffered 'imposter syndrome'; I was convinced that they had made a mistake admitting me, that they would discover this and would throw me out. But I am a bit of a fighter, so I remember saying to myself - I will work my very hardest so that when they throw me out, I won't have a guilty conscience. So I was being very thorough in checking those charts to really understand all the different kinds of signals that that new telescope produced.

Hannah: Tell us about the discovery. Did you have a sense it could be a new astronomical object right from the start?

Jocelyn: The first pulsar signal I had seen stuck somewhere at the back of my brain. Sure, it only took up about half a cm of chart paper (less than a normal source) but it was a problem - I couldn't pigeon-hole it! It was near the threshold of detection and often wasn't visible (visible only about one in 8 times that bit of sky was observed) but once I recalled that I had seen it before and from that bit of the sky I could track it back through my previous records.

Because it was all crammed into half a cm it was impossible to know what was going on, so with my supervisor's agreement I started a special observing campaign - going out to the observatory each day just before it would be visible to the telescope and switching to observe it using a high-speed recorder, so that the signal stretched over 15 - 20 cm. I did that for a month but it had faded/disappeared (we now know that was due to interstellar scintillation) and then it reappeared and showed itself to be a pulsed source.

Tony's first reaction was that it must be man-made, i.e interference, but I had been tracking this thing for months and knew that it kept sidereal time (kept its place amongst the stars) so I was fairly certain it was astronomical. However we had to go through a lot of tests to check that it really was astronomical and not something mimicking something astronomical - was there a problem with the wiring of the telescope? Could it be radar signals bouncing off the moon? What about the that big old aircraft hangar building just to the south of the telescope - could it be some sort of Bragg reflection off the corrugations? Could it be a satellite in a funny orbit with a period of 23hrs 56 mins? Etc, etc.

A colleague managed to get an estimate of the dispersion of the radio signal (due to free electrons in space which gives us a means to measure the source distance). The estimated distance put it beyond the solar system but within the Milky Way. Tony was still feeling it looked artificial so I kept observing and he kept checking the pulse period to look for Doppler shifts on it as 'they' on their 'planet' went round their 'Sun'. We did that about 6 months in total and found a Doppler shift - due to the Earth orbiting the Sun - but no other!

Pulsar chart recordings.

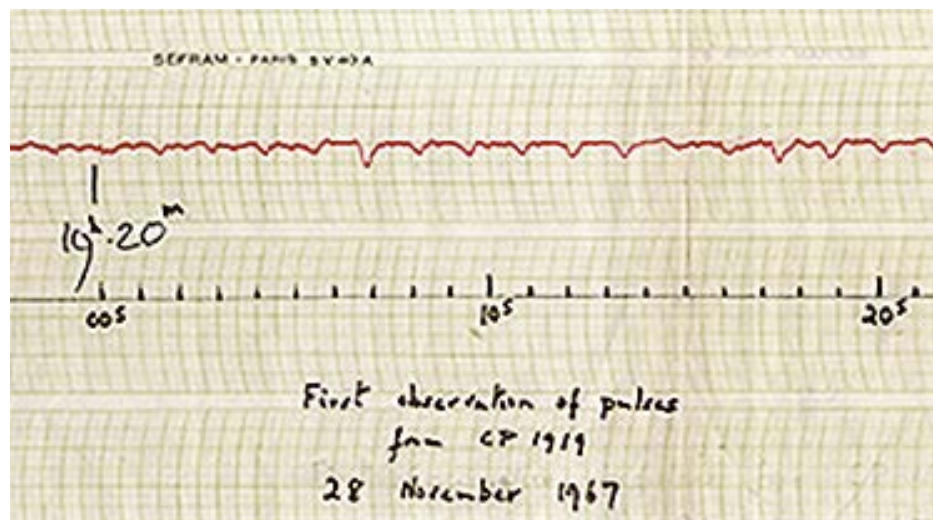

All that took about a month, and then I found the second one - in a technically very difficult part of the sky - that was really sweet, and confirmed that these must be a new kind of astronomical object. And a few weeks later I found the third and fourth.

Hannah: So although you felt it was astronomical, did you have an idea of what you would do if a signal from some intelligent life turned out to be the only explanation?

Jocelyn: I didn't really believe it was from extra-terrestrials, so hadn't thought this

through. However, I knew the dilemma of who to inform first - the Press, the Prime Minister or the Pope!

Hannah: In the LIGO-Virgo Collaboration, the first observation of gravitational wave was kept secret whilst the results were analysed and checked. Did you and your colleagues go through a similar process?

Jocelyn: Radio-astronomy was still quite a new subject then and didn't have full credibility with the astronomy community (for example radio astronomy was in the Cambridge physics department, not astronomy). So the whole group was always anxious not to make howlers. Added to that, this was such an unusual signal, which could so easily have been interference, that we weren't going to shout about it until we were sure we were on secure ground. We steadily involved more of the radio-astronomy group, because we needed more ideas of what tests to do, and in several cases needed their cooperation/equipment to do those tests.

Hannah: The discovery of pulsars went into the appendix of your doctoral thesis. Was that because you felt more proud of your other work over the course of your PhD?

Jocelyn: The pulsar discovery went in an appendix because Tony Hewish, my thesis adviser, said it was too late to change the title of my thesis - and I believed him. From what I now know of university systems, I'm not sure that was true. He also read the first draft of chapter 1 of my thesis, and said it read more like an after-dinner speech than a Cambridge University thesis (probably true!) and also said very firmly that it was my thesis so he wasn't reading any more. I decided that if it was my thesis the pulsars were going in - I wanted a contemporary and fuller account than could go in a paper - and an

appendix was the only way I could get them in.

Hannah: How has astronomy changed through the observation of pulsars?

Jocelyn: Clearly there is some extreme solid-state physics inside neutron stars. There are also some extreme electromagneto dynamics just outside the star. Both are actively researched, but I think it fair to say that as yet there is no complete consensus on either area.

They are very accurate 'clocks' and are being used as such to test several aspects of General Relativity. This is probably the area where most progress has been made. You will know about the first binary pulsar and the indirect detection of gravitational radiation (Hulse and Taylor) through the evolution of its orbit as energy is carried away by gravitational radiation. There is now a double pulsar which is in an even tighter orbit (and so is more relativistic) and is being used to test theories of gravitation (work of Michel Kramer et al). Even more recently a pulsar in a triple system (a pulsar orbits a white dwarf and that pair orbits another white dwarf) has been found. This is being used to test the strong-field principle of equivalence (work of Ransom and Archibald) - a modern and more relativistic version of Galileo dropping a hammer and feather off the leaning tower of Pisa to see if they fell at the same rate. You will also be aware of the pulsar timing array work to detect gravitational radiation from supermassive black hole mergers as galaxies merge. The last I heard on this topic was that they were finding fewer mergers than several theories predicted. So perhaps it is fair to say that pulsars have been putting many areas of physics to the test.

Hannah: I'm sure you've been keeping up with astronomy in general. What is it that most excites you at the moment?

Jocelyn: For much of my life I have been saying that we have been neglecting the low frequency radio domain and we have been neglecting the time domain. I am delighted that in the last few years both are coming back into fashion. There are a lot of low frequency telescopes now just starting work e.g. LOFAR, and at last the community is turning to the time domain. Gone are the simple supernovae classifications we were taught as students and fast radio bursts are one of the latest puzzles (current thinking seems to favour neutron stars!). Astronomy never gets boring!

Hannah: You are a well known and visible figure in astronomy. Looking back, how would you describe the evolution of your career in science?

Jocelyn: My 'career' in science can at best be described as a portfolio career. I got married as I finished my PhD and the places I worked and the kind of work I did were determined by his career moves and the constraints of bringing up a family.

Hannah: You are also active in encouraging diversity in STEM professions. What changes have you seen over the course of your career and what do you think we should be doing now?

Jocelyn: I was one of a small group of senior women who set up the UK's Athena SWAN awards, which recognises commitment to advancing the careers of women in science. I have been amazed how widely this award scheme has spread in the last decade - I keep waiting for the push-back! I hope what we have learnt about such schemes can now inform attempts to improve other areas of diversity (or lack of) including race, gender identity, and LGBTQ+, etc.

## The search for Continuous Waves

The observation of short duration gravitational wave signals from merging compact objects has obviously been the recent focus of the LVC. However, some of us are searching for continuous sources of gravitational waves: faint signals from rapidly-rotating and asymmetrically-deformed neutron stars within our Galaxy. Searches for continuous waves have a long and venerable history – the Crab pulsar in particular has been targeted for over 30 years. Since initial LIGO, Virgo and GEO600 operation, continuous wave searches have expanded greatly. Current efforts broadly fall into three categories: targeted searches for known potential sources with well-de-

fined spin frequencies; targeted searches for objects or sky areas from which continuous waves might be expected, but with some unknown frequency aspects; and all-sky searches where no source parameters are assumed. Continuous wave searches involve theoretical work, instrumental practice, coding skills, and signal processing knowledge. The group members, located all over the world and coming from various fields, work together to look for these tiny continuous-wave signals – about three to four orders of magnitude weaker than those detected from compact binary coalescence, but lasting for a very long time.



*Matt Pitkin*

*is a postdoctoral research fellow in the Institute for Gravitational Research at the University of Glasgow. He spends some of his time searching for gravitational*

*waves from pulsars, but most of it in the never ending task of clearing trains, tracks, cars, books, and assorted other toys from the living room floor.*



*Ling Sun*

*goes by Lilli within the LSC. She is a PhD student at the School of Physics of the University of Melbourne and worked in the IBM China System and Technology Lab before starting*

*her PhD. She enjoys travelling and photography, and typically runs one marathon or half-marathon every year.*



Continuous wave searches provided some of LIGO's early flagship results, with the known pulsar search from LIGO's second science run in 2003 leading to the first LSC Physical Review Letters paper, and the Crab pulsar search with LIGO's fifth science run (spanning 2005-2006) giving the first LSC Astrophysical Journal Letters paper. The continuous wave search for unknown sources also produced the widely used Einstein@Home distributed computing application, launched in 2005, which allowed the public to contribute to gravitational-wave searches long before most of the LVC's public science activities had begun.

◀ *This highly detailed image of the Crab Nebula combines data from telescopes spanning nearly the entire breadth of the electromagnetic spectrum: the VLA (radio) in red; Spitzer (infrared) in yellow; Hubble (visible) in green; XMM-Newton (ultraviolet) in blue; and Chandra (X-ray) in purple.*



We interviewed some continuous wave group members to get a flavour of the science currently being performed by the search group, and the people performing it. Below, we compile experiences from Pia Astone at Università di Roma “La Sapienza”, Joe Bayley at University of Glasgow, Ra Inta at Texas Tech University, Sinéad Walsh at the Max Planck Institute for Gravitational Physics, and ourselves.

Some of us started our careers outside the continuous-wave group. Sinéad started in particle physics working with the Compact Muon Solenoid detector. Pia pioneered gravitational wave burst and stochastic searches with the resonant mass detectors Explorer and Nautilus. Lilli started outside of astro(physics) entirely, working in information technology and software engineering. Ra, Matt, and Joe started working in continuous waves as PhD students, although Matt had done an undergraduate research project looking at infrared emission from the Jovian aurorae. He went into gravitational waves to pursue research in observational astrophysics, but without having to pour over many boring astronomical spectra – little realising that spectral analysis is ubiquitous in the physical sciences, and continuous wave work in particular! The excitement of entering a new field drew each of us in, with the data analysis challenges proving particularly enticing. Sinéad felt that “there was more opportunity to make a non-negligible contribution to this relatively new field, compared with particle physics”.

Pia has been involved in continuous-wave sources since the year 2000, first using the resonant bar detector Explorer. She recalls, “I first saw a known pulsar catalogue, the ATNF catalogue, where only 1000 (at that time) sources were listed, out of an expectation of the order of one billion. I thought it’s a pity that Nature gives us so many sources and we can’t see them!” She began looking for continuous-wave sources in the Galactic Center. “A lot of detector characterization work was

needed, exactly as it is now for analysis done with LIGO and Virgo.”

We took our first steps into continuous waves with a variety of projects, like analysing simulations and injections of potential sources, or looking into classic targets like the Crab pulsar and the remnant of Supernova 1987A. Ra wryly described his first project as “a badly conceived search parameter reduction scheme.” Today, Ra and Lilli are both working to target young supernova remnants. Ra is also investigating the potential neutron star candidate, Fomalhaut b, and Lilli is looking at neutron stars in accreting binary systems. “There are so many interesting and promising sources,” Lilli says, “but I guess my favourite one is Scorpius X-1. We have placed very sensitive upper limits on the gravitational-wave strain from the neutron star in Scorpius X-1 in the latest search using O1 data, although we have not detected anything yet.” Matt is looking for known pulsars: “The Crab pulsar is my favourite source, as much because it’s the first source I focused on searching for, as it is due to it being one of the most promising prospects for observable CW emission.” Sinéad is working on the Einstein@Home all-sky searches, Pia is expanding from her work on isolated and binary neutron star searches to also look for transient continuous-wave signals using advanced LIGO data, and Joe is testing a new un-modelled search algorithm.

Continuous wave searches are often computationally limited, in part because we must correct for the rotation and orbit for the Earth for every sky location we want to observe. Researchers must “find a compromise between sensitivity and computing cost,” says Sinéad. Creative research solutions are required: Ra recalls a pipeline bottleneck that could take weeks to run on a powerful computing cluster, such as AEI’s Atlas, until he sped it up with a Python library that is mainly used by bioinformatics researchers to compare gene sequences. Lilli’s group has collaborated with

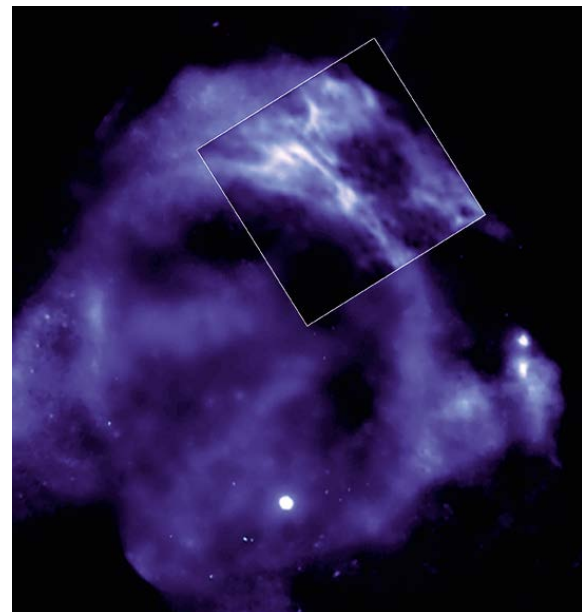

▲ *Circinus X-1 is an example of the class of objects called X-ray binaries, which also includes gravitational-wave favorite Scorpius X-1. It’s shown here in data from Chandra (blue) and the Australia Compact Telescope Array (purple).*

*The supernova remnant G347.3-0.5, as seen by Chandra (inset) and XMM-Newton. Chinese astronomers recorded a bright star in this location in 393 AD that was visible for about 8 years and rivaled the brilliance of Jupiter. The bright, point-like source on the lower section of the image is similar to other neutron stars and indicates that G347.3-0.5 is the remnant of a core-collapse supernova.*

the Electronic Engineering department to implement a method which has been used in engineering applications like radar analysis and mobile telephony, to efficiently track a “wandering” signal. “Communications and collaborations with experts in other fields help us open our eyes and come up with creative ideas”, she says.

Joe is currently working on un-modelled search, which can look for any type of continuous source which can have almost any frequency evolution. Unfortunately, he adds, “the search I am running is also quite good at finding instrumental lines within the data,” which he has suppressed in cases where there is a line in one detector and not the other, by penalising large differences in power between the two. “The most exciting moments are probably realising how sensitive the algorithm is, at least in Gaussian data,” he says. “The more disappointing moments are when the algorithm does not seem to do as well in real data, although we are slowly improving on this.”

As many of us in gravitational-wave science know, excitement and disappointment go hand-in-hand in an emerging field. Ra remembers a time early in his work where a signal he identified turned out to be a hardware injection: “That was something of an emotional roller-coaster, and I’m glad I didn’t share it with too many people!” Lilli shared a similar experience: “I got the first above-threshold statistic in my first search and then found it was an instrumental line. I thought ‘Wow we might have seen something!’ and then ‘Oh no... that’s noise...’” Stories like these weren’t restricted to people’s early work. Sinéad described how the Advanced LIGO first observing run’s all-sky search showed features which, unlike Initial LIGO’s results, seemed localized in the sky: “They were all noise. And every time we would exclude more noise we would see another candidate which looked more like signal, but it was always noise.” Through her 20-year career, Pia has remained

optimistic: “I can’t say I have ever been disappointed, as I am happy to fight to unveil these sources. Science proceeds with small steps and with many difficulties and, in any case, it is fantastic to be part of its progress.”

The continuous-wave group is looking forward to an eventual detection answering many questions about neutron stars, which are the densest stars in the universe, with conditions that can’t be reproduced here on Earth. “Once we hear the songs of neutron stars, we’ll know how a superfluid composed almost entirely of neutrons behaves, how the incredibly strong magnetic fields twist and tangle and annihilate, and so on,” says Lilli. Understanding neutron-star properties is the “bread and butter” reason to look for continuous-wave sources, and everybody is interested in the equation of state that describes neutron-star matter! But of course there may also be surprises. Ra is particularly intrigued by supernova remnants with nonthermal X-ray emission, such as Vela Jr. and G347.3-0.5. “The mechanisms behind such highly energetic remnant structures aren’t properly understood,” he says. “Surely there will be some aspect of continuous wave production that we haven’t considered.” Sinéad wonders what kind of unexpected object we might detect, and looks forward to having a contender for her favorite continuous wave source. Beyond the scientific appeal, Matt is looking forward to being a “pulsar astronomer” who can reciprocate when electromagnetic observers share their information.

Pia’s dream is “to give a name (not mine!) to a neutron star.” She says, “when I joined the effort I did not expect any detection during my life. Someone and someday for sure would have seen something and this was enough for me to go ahead.” Yet she holds a place in her heart for the unknown neutron star that we will first detect with continuous waves: “I am confident we will! It is there and we are approaching it.”



▲ Pia Astone at a public event, discussing how to overcome obstacles in both gravitational wave science and championship swim races.

Recent continuous wave papers from the LIGO Scientific Collaboration and the Virgo Collaboration:

- [1] First search for gravitational waves from known pulsars with Advanced LIGO <https://arxiv.org/abs/1701.07709>
- [2] Search for gravitational waves from Scorpius X-1 in the first Advanced LIGO observing run with a hidden Markov model <https://arxiv.org/abs/1704.03719>
- [3] Upper Limits on Gravitational Waves from Scorpius X-1 from a Model-Based Cross-Correlation Search in Advanced LIGO Data <https://arxiv.org/abs/1706.03119>
- [4] All-sky Search for Periodic Gravitational Waves in the O1 LIGO Data <https://arxiv.org/abs/1707.02667>

## Gravitational waves from 3 billion light years away

On June 1, 2017, the LIGO Scientific Collaboration and Virgo Collaboration announced the third confirmed observation of gravitational waves from colliding black holes. The gravitational wave signals were observed on January 4, 2017, at 10:11:58.6 UTC. This is the most distant gravitational-wave source observed so far: the merging black holes were between 1.6 and 4.3 billion light-years away. Details of the detection are published in “GW170104: Observation of a 50-Solar-Mass Binary Black Hole Coalescence at Redshift 0.2,” B.P. Abbott et al. (LIGO Scientific and Virgo Collaboration), *Phys. Rev. Lett.* 118, 221101. Below, we adapt some of Martin Hendry’s online Science summary to highlight key results.

The top two panels of Figure 1 show the data measured by the two LIGO instruments at the time of the merger. The GW170104 signal clearly displays the characteristic “chirp” pattern expected for the gravitational waves emitted from the merger of two black holes - i.e. a sharp upward sweep in amplitude and frequency as they orbit each other ever faster before they merge.

To find the signal with matched filtering, the data were compared to a bank of theoretical waveforms, to find the best match and extract some physical properties of the candidate source – such as its constituent

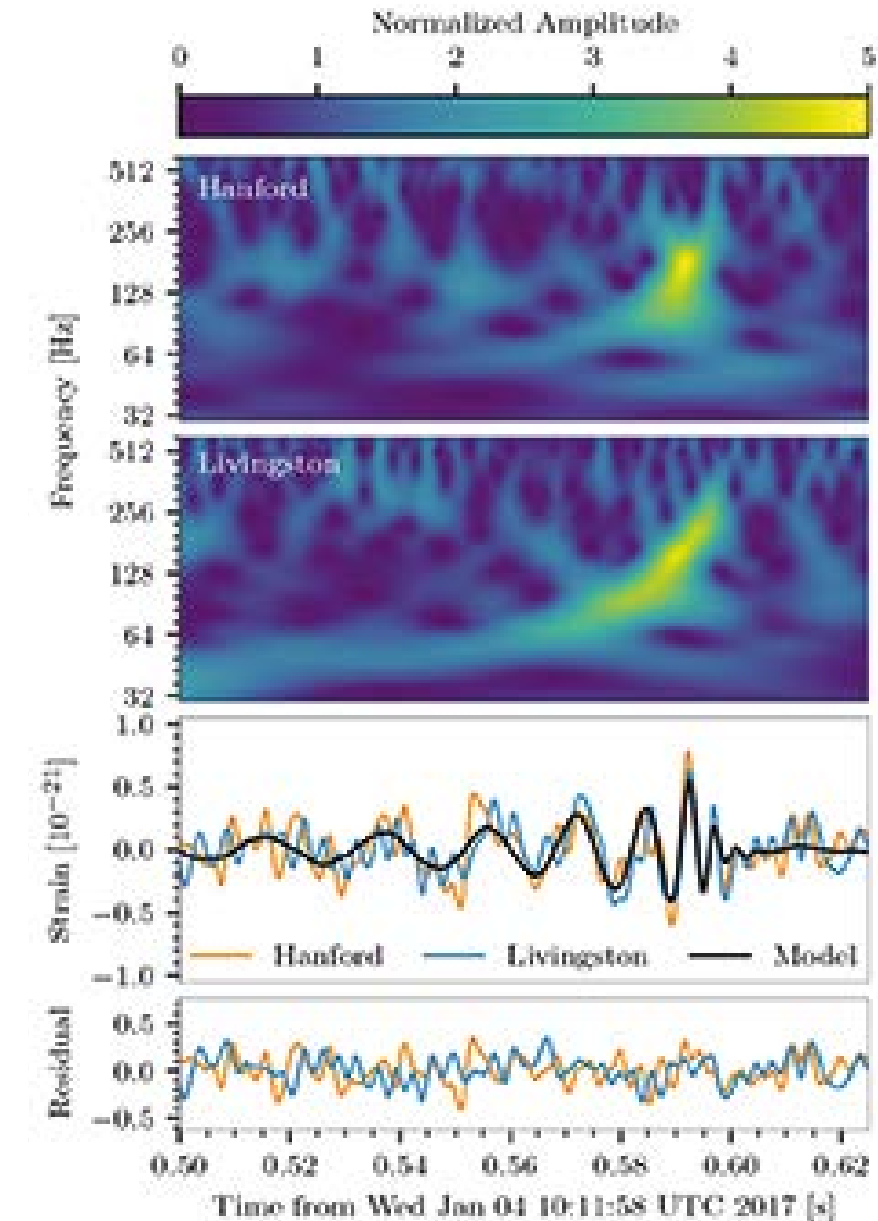

Figure 1 from the detection paper. Top two panels: Time–frequency representation of strain data from Hanford and Livingston detectors at the time of GW170104. Third panel: filtered time-series data from each detector. The Livingston data have been shifted in time to account for travel time between detectors, and inverted to account for the detectors’ different orientations. The maximum-likelihood binary black hole waveform is shown in black. Bottom panel: residuals between each data stream and the maximum-likelihood waveform.

masses and its sky position. The third panel of Figure 1 shows a comparison between the best-fitting waveform model and the time series data observed by the LIGO detectors at the time of the GW170104 merger event. The lowest panel shows the difference between these data and the best-fit-

ting model; we can see that the best-fit model gives a good match to the data.

Supercomputer analysis then allowed us to extract precise estimates of the parameters of GW170104 – i.e. the physical properties of the event, including the masses of the



# Detecting the GW170104 signal

merging compact objects, their distance from the Earth and position on the sky, the orientation of their orbital plane and constraints on the rate at which they are spinning and their orbit is precessing. The process of parameter estimation involves carefully checking millions of combinations of these model characteristics and testing how well the gravitational waveform predicted for each set of parameters matches the signal measured by the LIGO detectors.

We found the masses of the two compact objects to be about 30 times and 20 times the mass of the Sun respectively, indicating that GW170104 was the merger of a pair of black holes. We also estimated the distance of GW170104 and found that this event probably occurred about twice as far away as GW150914, at a distance of about 3 billion light years. In fact GW170104 is so remote that by the time its gravitational waves reached the Earth they had been stretched by about 20% due to the expansion of the Universe - a familiar phenomenon, known as the cosmological redshift, seen when observing the light from distant galaxies.

The large distance of GW170104 also allowed us to test another prediction of GR: that gravitational waves travel at the speed of light and, apart from the overall stretch due to expansion of the Universe, are not distorted. In some situations a wave can be dispersed as it travels through a material, meaning that the wave becomes distorted because components with different frequencies travel at different speeds. According to GR, however, the gravitational waves from GW170104 should not have been dispersed as they travelled across billions of light years to reach us.

Combining with our earlier observations of GW150914 and GW151226, we found that only a tiny amount of dispersion is

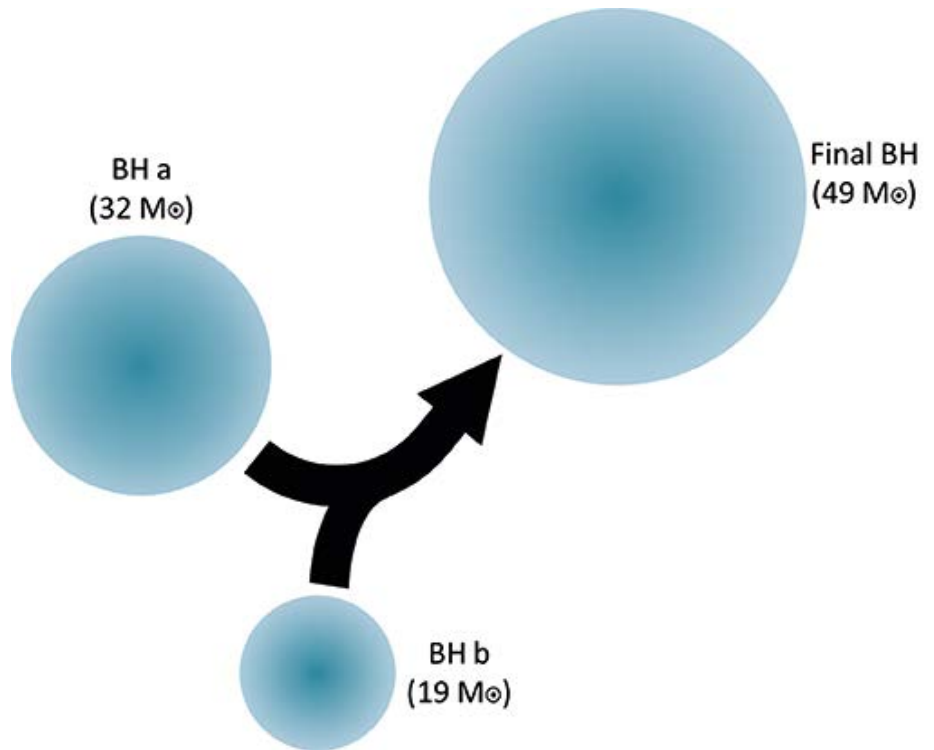

A schematic showing the relative sizes of the black holes before and after merging. The 90% credible range of masses is between 25 and 40 solar masses for the larger black hole before merging, between 13 and 25 solar masses for the smaller black hole before merging, and between 44 and 54 solar masses for the final remnant black hole.

The most likely spins of the two black holes that formed the binary. For the first time, gravitational-wave evidence suggests that at least one of the black holes' spins may have been misaligned with the overall orbital motion.

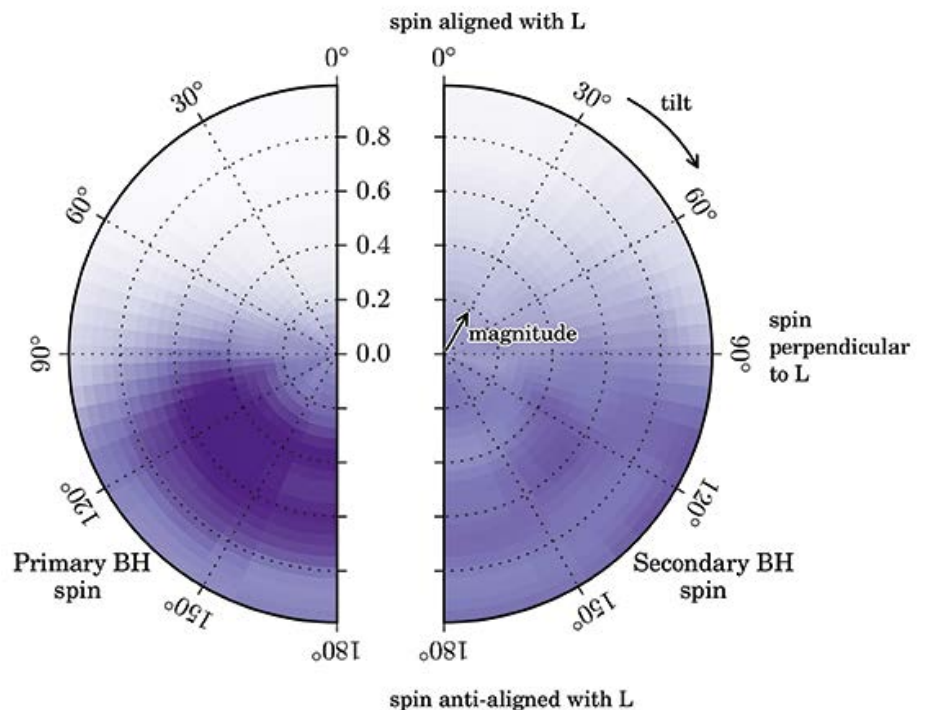

allowed in order to maintain consistency with our observations, meaning that GR again passed the test. Moreover, in one particular case our limits can also be recast to provide an upper limit on the mass of gravitons - quantum particles that make up gravitational waves in the same way that photons make up waves of light. Our new limit on the graviton mass, combining data from all three confirmed detections, improves by more than 50% on our previously published limits.

LIGO  
2017

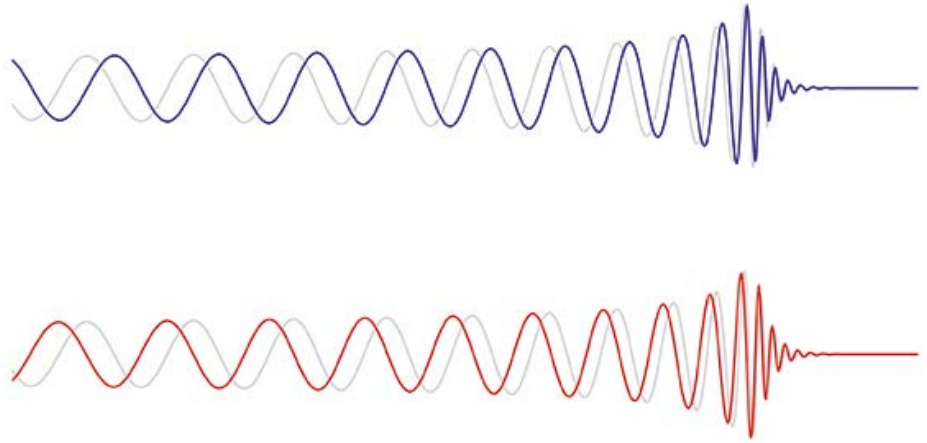

▲ *The effect of Lorentz invariance violating dispersion on binary black hole waveform, which occurs when waves travel at different speeds depending on their frequency. General relativity predicts zero dispersion. The upper and lower panels correspond respectively to GWs travelling slower than light (positive dispersion) and GWs travelling faster than light (negative dispersion). A nonzero graviton mass would result in positive dispersion. Combining data from all three confirmed detections we place an upper limit on the mass of gravitons of  $\leq 7.7 \times 10^{-23} \text{ eV}/c^2$ .*



GW170104  
LVT151012  
GW151226

◀ *On the left, the sky localizations of all the gravitational wave detections so far. **Below**, the estimated improvement in localization that would have been possible with a third second generation interferometer, Virgo, contributing to the detection.*

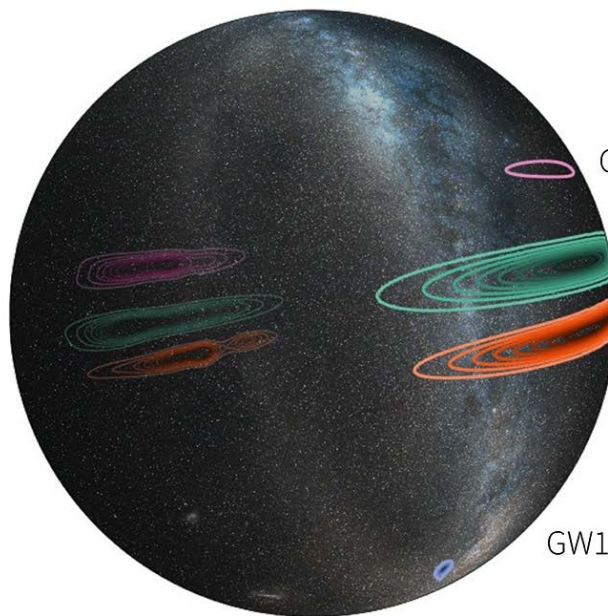

GW170104 +VIRGO  
LVT151012 +VIRGO  
GW151226 +VIRGO  
GW150914 +VIRGO

## Congratulations, Virgo!

On June 17, for the first time with Advanced detectors, LIGO Hanford, LIGO Livingston, and Virgo were simultaneously in a stable state and capable of joint astrophysical observations. The Virgo detector, located at the European Gravitational Observatory (EGO), joined Hanford and Livingston for a full triple-observing run starting August 1.



# CERN: A monument to human achievement

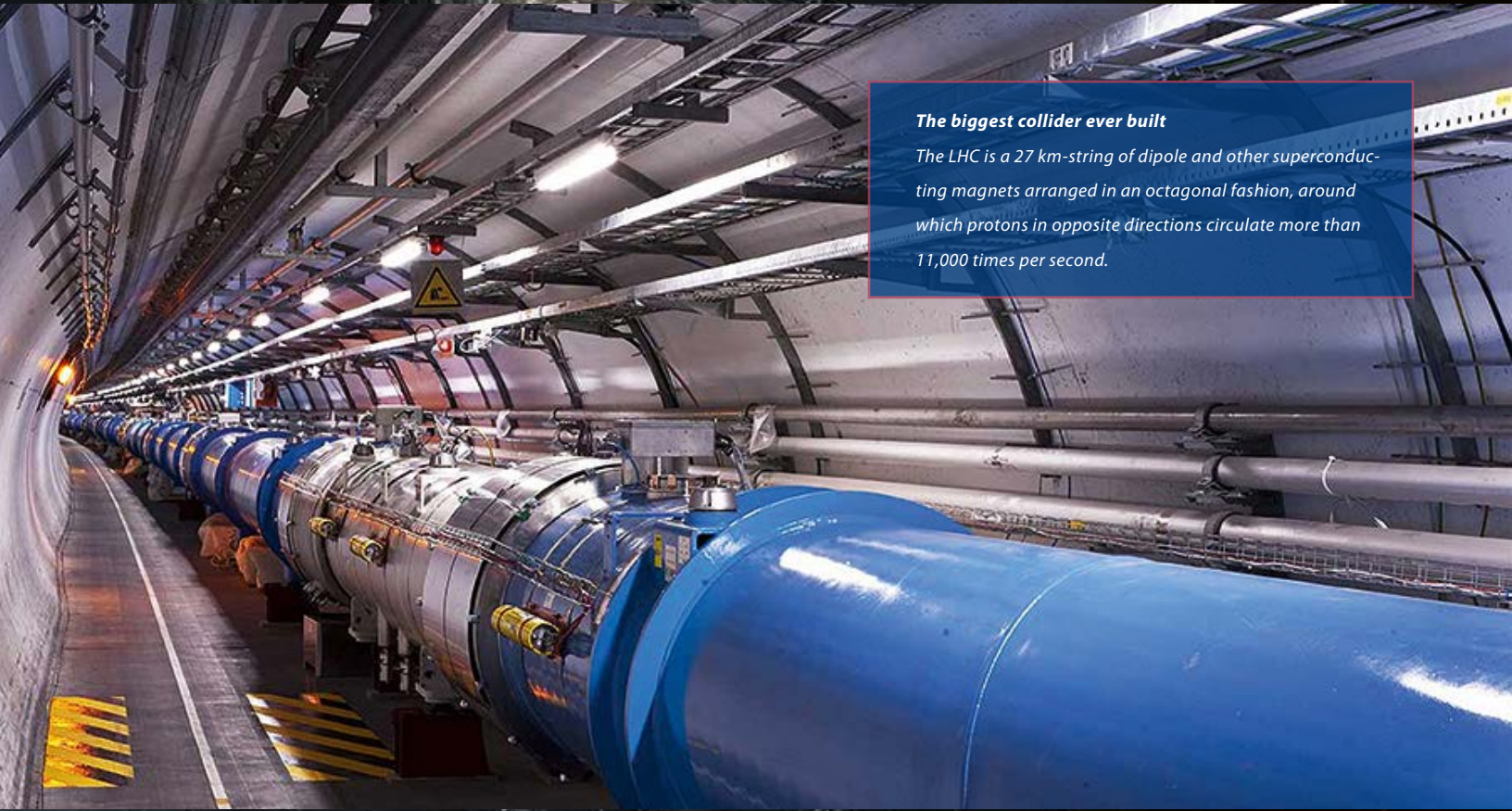

## **The biggest collider ever built**

The LHC is a 27 km-string of dipole and other superconducting magnets arranged in an octagonal fashion, around which protons in opposite directions circulate more than 11,000 times per second.

## Building big-physics experiments:

**B**eneath CERN's ramshackle surface buildings lies a monument to human achievement: a multi-billion dollar spectacle of technology and engineering called the Large Hadron Collider (LHC), built for no other reason than to explore the basic constituents of matter. Earlier this summer, this 27km-circumference ring of superconducting magnets resumed its second run following a six-month long technical stop. It is currently smashing protons together 100 million times per second inside massive detectors located at four points, streaming vast volumes of data to CERN servers which distributed worldwide for analysis via the Worldwide LHC Computing Grid – some 40 PB of data were written in 2016 alone.



### *Matthew Chalmers*

*is the editor of CERN Courier and did his PhD on the ALEPH experiment at CERN's former LEP collider in the late 1990s. Having written extensively on high-energy physics for 15 years,*

*he joined the Courier in May 2016.*

When the idea to build such a beast was first floated, Jimmy Carter had just entered the White House; the world's first all-in-one home computer had recently been unveiled, and Elvis Presley was about to die unexpectedly. It was 1977, and CERN's Director General at the time, John Adams, recommended that the tunnel that was about to be dug at CERN to house the LHC's predecessor, the Large Electron Positron (LEP) collider, be made wide

enough to accommodate a superconducting proton collider at a later date. The first official documentation of the LHC came during a meeting in Lausanne in 1984, and the project was approved ten years later. The machine finally switched on in 2008 amidst global media fanfare, and then suffered a massive electrical short that knocked it out for a year. After a successful restart at half its design energy, in 2012 the LHC made its first major discovery – a new elementary particle, the Higgs boson – and since 2015 it has been operating at near-design energy (13 TeV). A major upgrade in the early 2020s will increase the number of proton-proton interactions and see the LHC scour the high-energy frontier until the mid-2030s – more than half a century after the project was first conceived.



It is difficult to imagine how such a feat could be pulled off were it not for CERN's status as an intergovernmental organization and, in particular, its founding convention set out in 1954 (see panel on pg. 23). Not only does this model provide the financial stability vital to long-term projects, but it allows CERN to establish its own ways of working, for example when procuring equipment or services. Realizing the LHC's 1232 superconducting dipole magnets, each 15m long and weighing 35 tonnes, not to mention the world's longest cryogenic helium line to cool them all to a temperature of 1.9K, represented a contractual, technical and logistical challenge that was "beyond exaggeration", according to CERN's head of procurement and industrial services Anders Unnervik. Like many big-science experiments, the technology for the LHC largely

had to be invented, demanding the best of the world's minds and resources beyond what an individual country could afford.

#### Founding vision

That was precisely the vision of CERN's founders 70 years ago. The second world war had driven many top physicists, famously including Einstein, to the US, where some went to work on the Manhattan Project, fearing Germany's physics powerhouse would get the bomb first. By the end of the 1940s, a group of physicists and diplomats had proposed a new European laboratory to stem the flow of talent, convinced that Europe's post-war reconstruction should be driven by developing its fundamental research tools. In 1952, the Conseil Européen pour la Recherche Nucléaire (CERN) was formed under the auspices of

UNESCO, leading to the establishment of the Organization via a convention signed by 12 member states in September 1954. Its remit was to carry out peaceful research, educate and train the next generation, and to make all of its work publicly available.

Back then, physicists were trying to make sense of numerous subatomic particles that were turning up in experiments and cross-national collaboration was the only way to build the bigger particle accelerators they needed. CERN's inaugural machine, the 600MeV-energy

*The ALICE A Large Ion Collider Experiment. This project involves an international collaboration of more than 1500 physicists, engineers and technicians, including around 350 graduate students, from 154 physics institutes in 37 countries across the world.*

## The CERN model

#### The LHC experiments

Four giant experiments stop and track the debris from the LHC's proton-proton collisions. Each is, in a sense, a global collaboration in its own right (CMS and ATLAS each have more than 3000 people working on them) and technically are not under CERN's governance.



THERE WAS A TIME WHEN I WASN'T SURE IF I WANTED TO BECOME AN OPERATOR.

BUT WITH SUPPORT FROM FROM MY SUPERVISOR AND FRIENDS.

I THINK IT'S A GOOD IDEA.

PLUS YOU'LL HAVE "BEEP" TONS OF SAVINGS!

AND THE NAGGING VOICE IN MY HEAD.

YOUR GPA LOOKS LIKE "BEEP" YOU'RE NOT GETTING INTO GRAD SCHOOLS WITH THIS.

TRANSCRIPT

I DECIDED TO GIVE IT A SHOT.

"APPLICATION SUBMITTED"

2 MINUTES LATER

"APPLICATION REJECTED"

"BEEP"

I THINK I ENDED UP GETTING THE JOB THROUGH THE PEOPLE I MET AT THE LVC MEETING.

YOU SHOULD TALK TO THIS GUY.

thanks!

(THANK YOU JENNE, MIKE!)

AFTER ONE PHONE INTERVIEW.

HOW WOULD YOU APPROACH PEOPLE YOU DON'T KNOW?

PLAY DUMB?

EH... THANKS FOR YOUR CANDID ANSWER.

AND ANOTHER F2F INTERVIEW.

HOW MANY NON-SPINNING BLACK HOLES DO YOU THINK ARE OUT THERE?

SHOULD I KNOW THE ANSWER?\*

\*MY ANSWER WAS 4/10 BECAUSE MOST (IF NOT ALL) OBJECTS IN THE OBSERVABLE UNIVERSE ARE ROTATING.

I RELOCATED TO RICHLAND, WA.

WAHH!

PRETTY MUCH EVERYONE HERE IS FRIENDLY.

ASK US ANYTHING

SOME ARE FRIENDLY BUT DON'T SHOW IT VERY WELL.

WHAT DO YOU WANT?

(BTW, HE ALSO TALKS TO HIS DAUGHTER LIKE THAT)

WHAT DO YOU WANT?

THE HEAD COMMISSIONER IS VERY LAID BACK (AND VERY SWISS)

WHAT DA "BEEP" IS GOING ON?

OUR GDS ADMIN ONLY SPEAKS IN ACRONYMS.

I'M GOING TO RESTART BLANK, BLANK, AND BLANK

AND THIS WILL AFFECT BLANK, BLANK, AND BLANK.

AND THE SITE HEAD IS A HOCKEY GOALIE (HE ALSO RUNS KIDS GOALIE SUMMER CAMP).

THIS IS HOW YOU PUNCH.



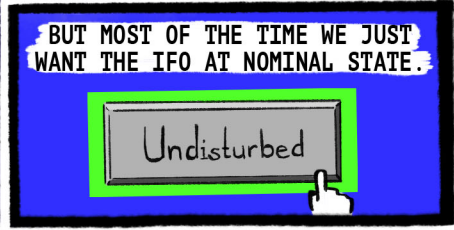
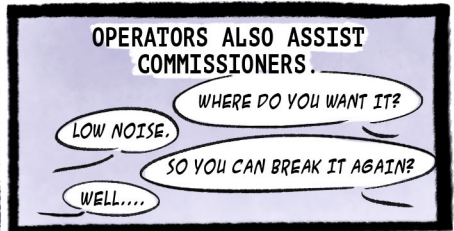

\*JUST LIKE DOCTOR WHO'S TARDIS, GUARDIAN SOMETIMES NEEDS TO BE NEGOTIATED WITH.

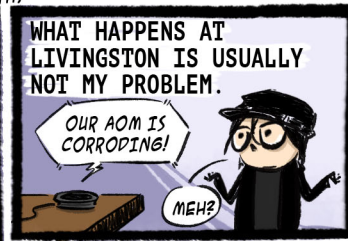
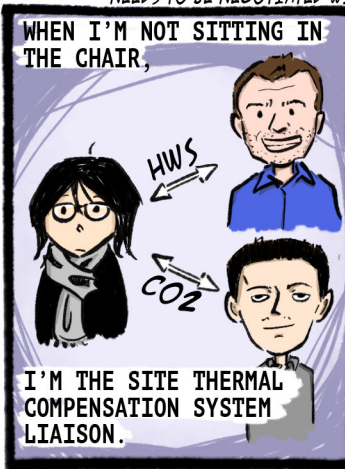

\*SORRY FELLOWS. I CAN'T FIT ALL OF YOU IN ONE PANEL!



YES, OUR BLUEGRASS BAND HAS A PIANO. SCREW THE TRADITIONS!

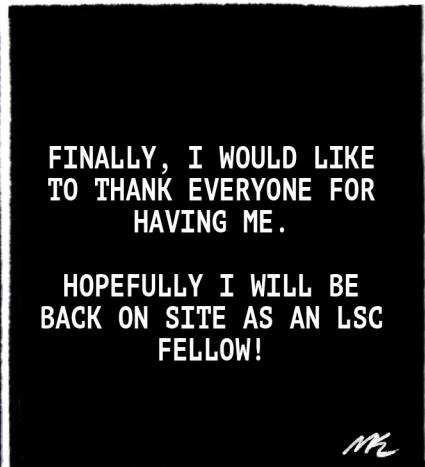
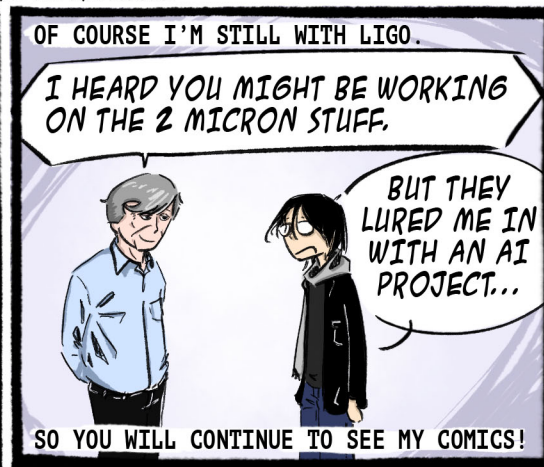

ML



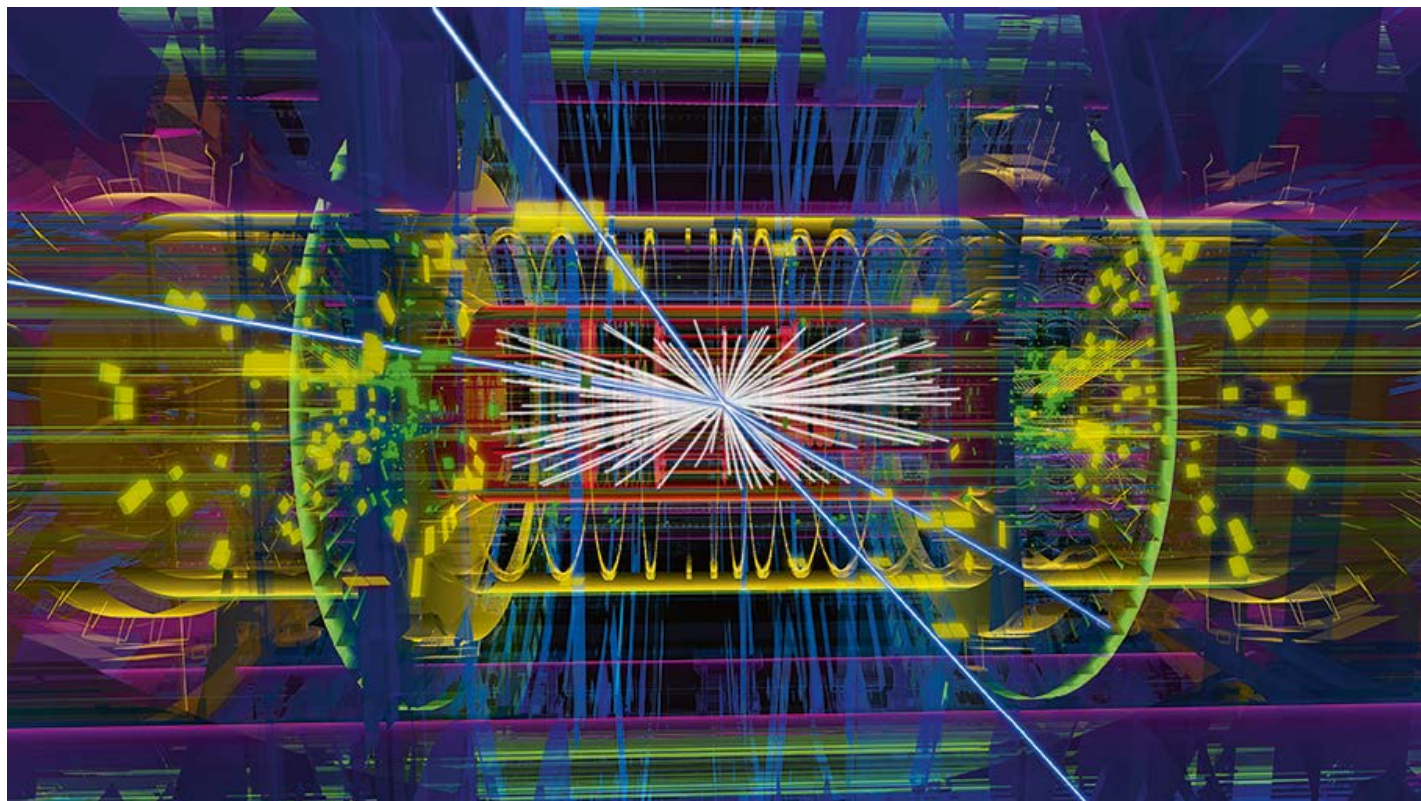

Synchrocyclotron, now an exhibit for visitors to the Geneva lab, fit into a large room; its latest tool – the LHC – is more than 10,000 times more powerful and would encircle a small city. The evolution of colliders at CERN and elsewhere, in conjunction with immense achievements in theoretical physics, delivered us the Standard Model of particle physics, for which the LHC’s discovery of the Higgs boson was the icing on the cake. Yet, had a fateful decision in the US in October 1993 gone a different way, the Higgs might have been discovered earlier and CERN could look very different today.

### Lessons in going it alone

In 1987, US Congress approved the \$11B, 87km-circumference, 40TeV Superconducting Supercollider (SSC), only to cancel the project six years later due to cost overruns and management issues. Significant sections had been excavated and hundreds of people moved to the Texas site, but the SSC was to become a lesson in the difficulties of going

▲ *More than just pretty pictures, event displays such as this one from ATLAS in which four energetic muons (blue) emerge from a high-energy proton-proton collision, are important tools for understanding the massive detectors and for studying the underlying physics of elementary particles.*

it alone with long-term projects within the constraints of national politics and under intense public scrutiny. The LHC, which is less powerful than the SSC but based on more innovative magnet technology, was given the green light by the CERN Council within a year of the US machine’s demise. Many particle physicists in the US packed their bags and headed East.

Building the LHC was no walk in the park, though. Back in 1977 it was all very well talking about superconducting accelerators, but the technology was in its infancy. Developing and building the magnets would consume half the LHC budget and drive other CERN experiment programs to a minimum. Initially CERN management proposed a less

costly “missing magnet” version of the LHC, which contained fewer dipoles that would operate at a much reduced energy in an initial stage. The Council approved the idea, contingent on funding being secured from non-member states for the second phase of the project, and LHC project director Lyn Evans and company set off on a world tour to drum up support.

The effort paid off: Japan declared a major contribution in 1995, followed by India, Russia and Canada. One year later, the US ploughed half a billion dollars into the LHC, and the missing-magnet machine was consigned to history. CERN still had to max out its credit card to build the collider that is in operation today, however, and the project suffered several years of delays. But, as Evans points out, the LHC is its own prototype – all in all, he says, representing a “mammoth task on a massive scale” that pushed technology and international collaboration to its limits.

## Inspired organization

It is worth imagining what else might be possible were a model like CERN's adopted – cracking room-temperature superconductivity? Solar cells with 99% efficiency? Electricity from fusion reactors? So far, it is user-based facilities, rather than one-off Apollo-like projects with a single goal, that seem to have adopted a CERN-like approach. The European Southern Observatory (ESO), which provides state-of-the-art astronomy research facilities such as the VLT and ALMA telescopes, is closely modelled on CERN. Indeed, the idea for ESO was discussed at the very time as CERN was founded, and ESO was physically located at CERN for a while. From five original member states, ESO has grown to 16 which contribute more than EUR 200M per year, and currently the organization is working towards its own LHC-class project: the European Extremely Large Telescope, which will gather 13 times more light than any other optical telescope in existence. The European Space Agency (ESA), established in 1975 and today numbering 22 member states, was also modelled directly on CERN "on the basis of scientific and technical principles and not on the basis of political and commercial arguments".

More recently, the CERN model has been applied to the SESAME light source in Jordan – a third-generation synchrotron governed by a council made up of representatives from Cyprus, Egypt, Iran, Israel, Jordan, Pakistan, the Palestinian Authority, and Turkey. SESAME was founded, like CERN, under the auspices of UNESCO in 2004. Inaugurated earlier this year, it aims to encourage peaceful scientific collaboration in the Middle East and neighboring regions, and CERN and the European Union (EU) have been important partners in producing the SESAME magnets.

Around the same time the LHC was dreamt up in the late 1970s, scientists in Europe also proposed the European Synchrotron Radiation Facility (ESRF) in Grenoble, France. Elev-

en countries signed the ESRF Convention and Statutes of the ESRF in Paris in 1988. Today the facility has 13 member states (with Russia the most recent to join) and nine scientific associates, together contributing approximately €100M per year. Its governing body is the ESRF Council and in the facility's organizational DNA is the dissemination of synchrotron instrumentation and techniques to other light sources in Europe and beyond. The ESRF, or "European Synchrotron" as it is rebranding itself, is currently embarking on a major new machine that will produce more brilliant X-ray beams. Despite numerous third-generation synchrotrons springing up in the ESRF's member countries during the past decade or so, competition for beam time at the Grenoble lab is as tough as it ever was.

Helping to combine and coordinate the resources and expertise of such European intergovernmental organizations – which also include the Institut Laue-Langevin (ILL) neutron source in Grenoble and the European Molecular Biology Laboratory (EMBL) headquartered in Heidelberg – is the EIROforum body. Going beyond Europe, ITER – the massive fusion experiment now under construction in France – is an intergovernmental organization that was established by an international agreement signed in 2006 by China, the EU, Euratom, India, Japan, Korea, Russia and the US, which is meant to last for at least 30 years. The project has suffered a series of delays, for instance concerning its location, but is arguably the most technologically audacious that mankind has ever attempted. In a similar class, at least concerning its political complexity, is the International Space Station (ISS), which was built and is operated by a partnership of space agencies in Europe, Canada, Russia and the US.

There are, of course, many other ways to organize today's big-science facilities which differ from CERN's approach. The €1.8B European Spallation Source (ESS) to be built in Sweden,

for example, was established by the European Commission as a European Research Infrastructure Consortium ("ERIC") and is governed by the ESS Council, with 15 founding member and observer countries. Then there is the €1.5B FAIR (Facility for Antiproton and Ion Research) in Germany which, following a decade of difficulties, began construction this summer. FAIR is registered as a German company (GmbH) with nine major shareholders: Finland, France, Germany, India, Poland, Romania, Russia, Slovenia and Sweden. Finally, entering user operation this year is the world-leading €1.2B European X-ray Free Electron Laser (XFEL) in Hamburg, a next-generation light source with around a

*A big factor in making the LHC possible was the existence of a ready-made tunnel, previously home to the Large Electron Positron collider (LEP). The excavation of the LEP tunnel was the most formidable civil-engineering venture in CERN's history and Europe's largest civil-engineering project prior to the Channel Tunnel.*

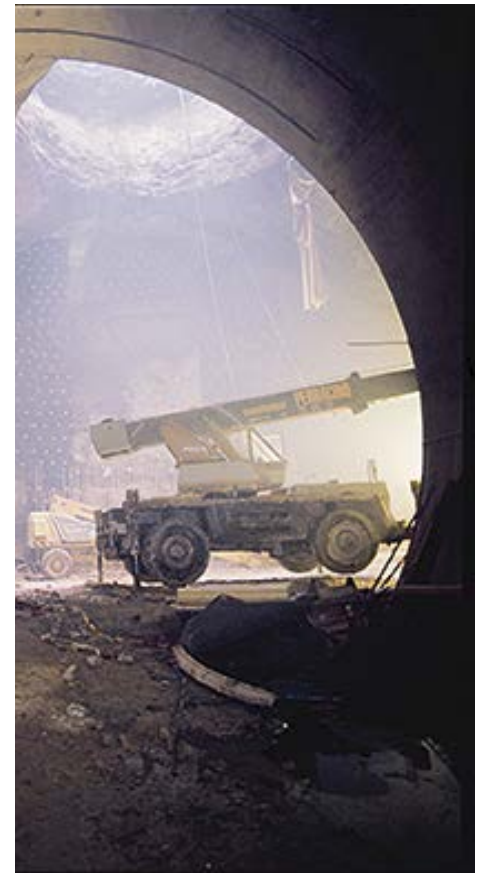



# CERN: A monument to human achievement

dozen major shareholders, mainly Russia and Germany, that is also a EIROforum member.

## Going global

Whether it is the strength of its founding principles, or the particular nature of high-energy physics – with its large geographical distribution and relative consensus on what the next big facility should be – CERN is clearly a model for what Europe can do when it unites. The LHC is its most impressive achievement so far, though CERN's spirit of openness and collaboration has also impacted the wider world. Witness the way the protocols for the Web were made open-source so soon after Tim Berners Lee's invention 28 years ago while he was working in CERN's computing department, and the Organization's long-standing commitment to open-access publishing. CERN also has a long and growing list of examples of successful knowledge transfer, for example concerning computing, medical-imaging and the rapidly expanding field of hadron therapy.

Of course, a good organizational model is just one ingredient for CERN's success. Projects such as the LHC also benefit enormously from the scientific environment of high-energy physics. For example, large experiment collaborations are led by a spokesperson who is able to guide consensus-building and enable the collaborations to operate. CERN itself engages several high-level peer-review committees that scrutinize the scientific programme, with progress closely monitored by the Council. This generates an efficient organizational environment in which scientific excellence can thrive.

To continue in our journey to understand the basic workings of the universe, however, CERN and the wider particle physics community face a big decision that will test organizational models to the limit: what machine should come next after the LHC? Several options are on the table, ranging from a fairly



▲ *The CERN seminar on 4 July 2012 at which ATLAS and CMS announced that they had each found overwhelming evidence for the existence of a new boson with a mass of around 125GeV. The discovery is on a par with the direct detection of gravitational waves by LIGO, three years later, opening a new line of exploration into the interactions between particles and the basic structure of the vacuum.*

conservative energy upgrade of the LHC to a high-precision, high-energy linear electron-positron collider and, most audacious of all, a 100km-circumference proton-proton collider with an energy of 100 TeV that could also house an electron-positron collider. The latter was launched as part of the CERN-coordinated Future Circular Collider study in 2014. Geological surveys in the Geneva region have been undertaken, and already physicists and engineers are working out how one might produce the magnets, twice as powerful as the LHC's, to fill it. Were such a machine to get the go ahead, it is sobering to think that its discoveries will likely be made by people who are yet to be born, let alone wonder who might occupy the White House.

It is also difficult to see how any post-LHC machine can be realized without global organization. The price of big-ticket future circular colliders, for instance, will necessarily shift from the few-billion to the low-tens of billions. Yet, so far, examples of formal global collaboration are few, and the organizational challenges involved are considerable. One of

the biggest stumbling blocks for ITER over the years, for example, has been in reaching agreement about which country should actually site the thing, given the assumed benefits such projects bring to host nations. At least with the ISS, surely the stand-out example to date of international scientific collaboration, its location was not an issue.

CERN is already growing into a global laboratory. The lab has expanded from its 12 founding member states to 22 in the past six decades, and also numbers many associate members and observers (see panel). The LHC alone has doubled number of physicists who are involved with CERN in a period of just 10 years – which is one of the reasons why you have to time your lunchtime trip to the main cafeteria well if you want to guarantee a table these days. Director of Accelerators and Technology, Frédérick Bordry, cautions that it is important not to go too far too fast: "If you think about it, there is very little worldwide organization that is truly effective, so we need time to learn how to organise humans on a global level."



# CERN – Conquering by Convention

The CERN Convention lies at the core of the Organization's strength and stability over the past 63 years. The document resides with UNESCO in Paris where instruments of ratification, which are adopted at national level, are deposited. The CERN Council, which stems from the CERN Convention and typically meets four times per year, defines CERN's strategic goals and approves its budget based on proposals by the Director General, who is the organization's chief executive officer and legal representative (and who is also appointed by the Council). Membership of CERN secures a country a Council seat, with two delegates per country.

Some 90% of CERN's CHF1.2B budget comes from annual subscriptions from its member states. Each contributes a sum linked to its net national income, which is recalculated each year. Full membership costs the largest contributors (Germany, the UK, France and Italy) upwards of CHF100M per year. Associate membership, which requires countries to pay a minimum of 10% of what their contribution as a member state would be, doesn't buy the full benefits of membership but allows a country to take part in council discussions. In return, citizens of member and associate

member states may apply for fellowships and staff positions and firms can bid for CERN contracts. CERN adopts the concept of "fair return" regarding tendering and subcontracting, to ensure that all its members – including the host states France and Switzerland – benefit equally.

Japan, JINR, Russia, UNESCO and the US are currently Observers. In addition, CERN has established around 50 International Cooperation Agreements with non-member states. In 2012, CERN was granted Observer status at the United Nations General Assembly, and increasingly its Directors

General are present at high-profile gatherings of world leaders such as the World Economic Forum's annual Davos event.

Quitting CERN is a rare occurrence. In 2009, 50 years after joining as CERN's 13th member state and contributing around €20M annually, Austria signaled its intention to leave but, faced with strong arguments from its scientists, did not carry the decision through. Spain, which joined in 1961, left the laboratory in 1968 but rejoined in 1983 – the year when CERN's

Super Proton Synchrotron unearthed the W and Z bosons. Even the UK, one of the original 12, was weighing up its membership around that time, facing pressure from other science disciplines sensing an unfair distribution of resources. The only country ever to have pulled out proper, also one of the original 12, was Yugoslavia in 1961. Yet, today, a number of the countries of the former state are rejoining the CERN family.

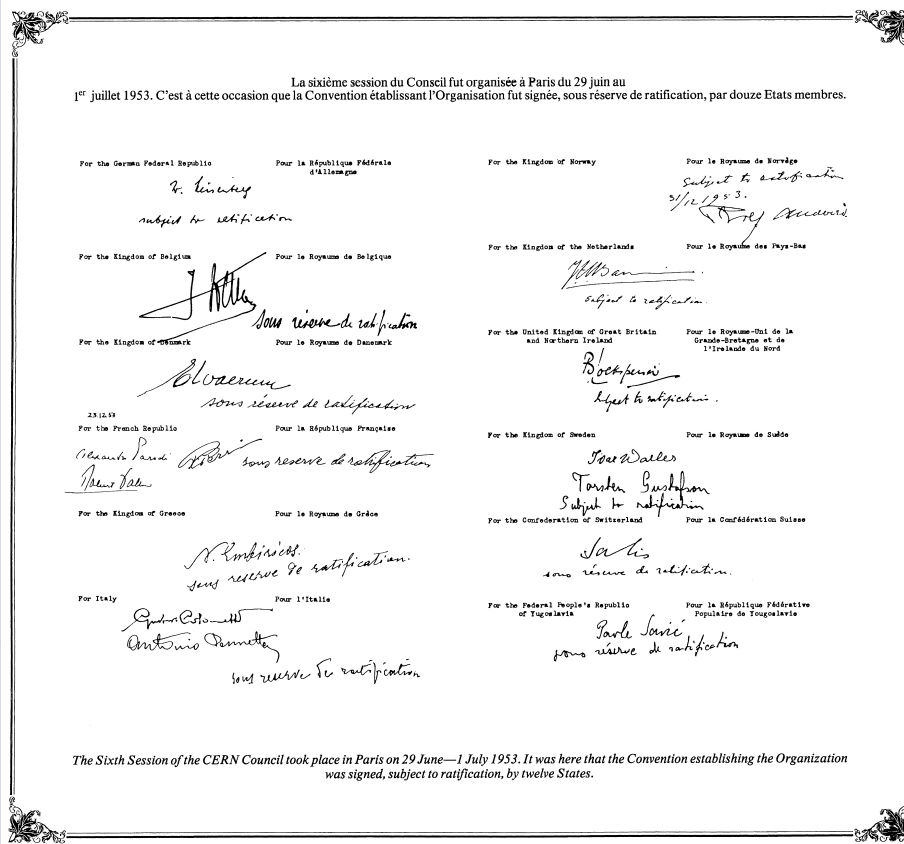

The Sixth Session of the CERN Council took place in Paris on 29 June–1 July 1953. It was here that the Convention establishing the Organization was signed, subject to ratification, by twelve States.

Since 2010, CERN has pursued a geographical enlargement strategy, and last year Romania became the laboratory's 22nd member state. Its associate membership has also expanded to seven, with Slovenia the latest to join this year and Lithuania poised to conclude the process soon. Brazil, Croatia and Russia all have applications in process, while interest has been expressed in Ireland, Estonia and Latvia. The European Commis-

## Goodbye LPF! Hello LISA!

**L**ISA Pathfinder has been switched off as planned on the evening of 18th of July, ending a successful mission which surpassed all expectations.

After 16 months of science measurements, the LISA Pathfinder (LPF) team deactivated the satellite on the evening of the 18th of July 2017. LISA Pathfinder powered down after receiving the last commands and now it circles the Sun on a safe parking orbit. "Sending the final command was a bitter-sweet moment", Principal Investigator Stefano Vitale and Co-Principal Investigator Karsten Danzmann admitted. "LISA Pathfinder worked fantastically, it was not easy to let it go. On the other hand we are looking forward now to realizing LISA."

The End-Of-Mission Ceremony was embedded in a LPF review meeting at ESA's European Space Operations Centre (ESOC) in Darmstadt, Germany. During the meeting scientists, engineers and operators recapped the mission and worked on a detailed documentation that will retain the knowledge and enable the succeeding LISA team to work on the future mission smoothly.

### After working on LISA Pathfinder for so long, how does it feel to turn it off?

**Stefano Vitale, LPF PI:** The word of the day is: Done. And well done. It has been such a rewarding experience. All the team is proud. Now we have to move on to LISA, and so it is no regret.

**Karsten Danzmann, Co LPF and LISA PI:** There may be withdrawal symptoms. It will be a big change after so many months of receiving

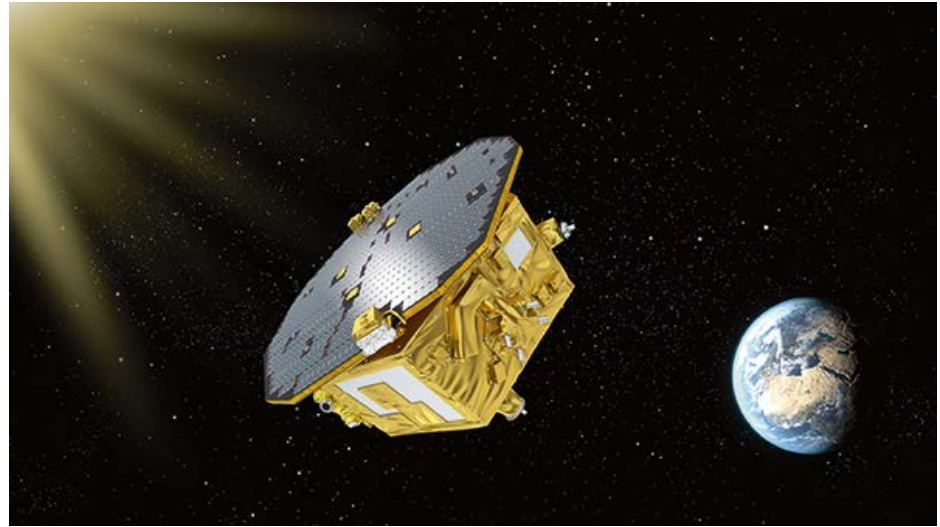

*As a gravitational-wave laboratory in space, LPF has tested key technologies for LISA. The results show that the required technology for the LISA mission is already working optimally: LPF's measurements surpassed the expectations of all scientists involved.*

daily science data from outer space, but we have a lot of data left to analyze. And now we can concentrate on the big mission and start working on LISA.

**Paul McNamara, ESA Project Scientist for LPF:** I'd say it's bitter-sweet, because today we are turning it off and it ends and it's been a part of my life for the last 12 years. But the legacy we carry on for many years. We'll be analysing data, writing papers, and then what we've learned on LISA Pathfinder will feed into LISA. So I say it's bitter-sweet, because the sweet part is LISA was selected by ESA just the end of June and this will be the next large class mission in the science program. So one mission is ending, but the next one is starting. Hopefully everything that we learn from LPF will enable us to build LISA.

**Oliver Jennrich, ESA Study Scientist for LISA:** The last two years or so were extremely intense, certainly. Ok, we killed the mission today, but from my point of view it is more a transition to LISA. I think it is inevitable that LISA Pathfinder has to go, so that we can free our brains and switch over to the mode: Let's build LISA. And yes, we don't kill missions very often, but maybe we learned almost all of LISA Pathfinder that we could learn.

### What was it like to work on LISA Pathfinder operations?

**Stefano:** It is magic. You tell the satellite: do this experiment, and then the data comes back and says: done. I have done this experiment, these are the data. It was magic every time. I mean: having this data on my desk, and this data comes from one and a half million kilometres away, this is really pure magic. That was LISA Pathfinder. A high-precision physics laboratory that worked beyond expectations, only instead of in the basement, it was one million km from the Earth. But it was the same: you go to your laboratory in the morning, you do your experiments, they work, the machine is working like a dream... and that was LISA Pathfinder.

**Karsten:** There is one moment that I will probably never forget, and that is when we released the proof masses on the first day of mission operations. That is a tricky business. They have to be tightly caged during the launch vibrations because the rocket is rattling around with a lot of force, and so we hold them with a force that is almost equal to the weight of a small car. And then you are in orbit and you have to release the proof masses, a very delicate process. It is done

in two stages: first, you release the big pre-load and after that you have small plungers that very delicately, carefully release the masses themselves. And we did the first step, we took off the really high-force plungers and then there was this magic moment because the proof masses were suddenly floating in free space. Nobody had expected that at that early phase of the mission. We were all stopping in the control room, not carrying on, just observing the signal from there. The controllers were already getting impatient, saying can we go on now? But the scientists were just watching the signal of two gold cubes floating in deep space. That was an incredible moment.

## What do you consider the most important result of LISA Pathfinder?

**Stefano:** We have demonstrated the possibility of doing the pure geodesic motion that Einstein was claiming as the key element to measuring gravity. We have pushed this ability by more than a factor 1000, we have done a factor 1000 better than anything that has been done before. And this opens new doors not just to LISA, but to the field in general. The ability to do this is a major leap forward.

**Oliver:** We certainly learned that we can actually build these instruments very much better than we thought.

## What was the most valuable lesson you learnt from the mission?

**Stefano:** From the point of view of the mission operations, LISA Pathfinder is a different kind of object, relative to other missions. It is one instrument that includes a spacecraft. Actually, LISA is one instrument that includes three spacecraft. This forces engineers, colleagues from industry, from agencies and scientists, to work together as a single team. And this worked very well in LISA Pathfinder, it was a very rewarding experience, the group was enthusiastic, believed in the project, we could overcome the difficulties, and I think it is a major added value to the space business in general.

**Karsten:** LISA works. That is the most important lesson we learnt from LISA Pathfinder. There are no surprises.

**Paul:** To me the one really valuable lesson is the first day we turned on LPF, it had met our requirements, it had done what we asked for. And over the duration of operations it got better and better and better. But what it demonstrated is that European industries can build a mission like LISA. We know how to do it.

## The next space phase will be in the 2030's. How can you ensure that the experience from LPF is passed to the future?

**Karsten:** Space projects can last for decades. It is always a challenge to transfer the knowledge from one generation of scientists to the next. The best thing you can do is never stop, always have overlapping generations of researchers, so that one generation can teach the next. If you take a break, then knowledge gets lost. We have been in a fortunate situation in that we have always had a continuity of people. It is very fortunate too that the technology of LISA is also useful for other missions, for example for earth observation missions. LISA Pathfinder has taken many years, but it was really a breakthrough and we are ready for the big mission.

**Paul:** I think the first thing is, we get young people. I actually started to working on LISA in my PhD, and for the last 23 years I've been working on it. These missions take a very long time. What we can do is, we train people. We take young people to train them up. We had a wonderful team including many young researchers working in the operations of LPF. And that will be the next generation for LISA. Of course we also have documents, you have to write everything down which we think could help us in the future. But the reality is it's people.



LIGC<sub>2017</sub>

◀ *LISA is scheduled to be launched into space in 2034 as a mission of the European Space Agency (ESA). US scientists are currently evaluating how NASA could participate in the mission. LISA will consist of three satellites spanning an equilateral triangle with each side 2.5 million kilometers long. Gravitational waves passing through the formation flight in space change these distances by a trillionth of a meter. LISA's observations will complement detections by earthbound instruments by measuring low-frequency gravitational waves.*



# The 100 hour Glasgow-Garching run

*David Robertson*



*works on building interferometers for space based gravitational wave detection at the University of Glasgow and is currently analysing LISA Pathfinder data. In his spare time he enjoys running, sometimes up mountains with his children.*

*David Shoemaker*



*is a Senior Research Scientist at the MIT Kavli Institute. He spent a truly enriching couple of years in Garching in the mid-80s, learning physics, German, and beer drinking. He is currently the LSC Spokesperson.*



## The first joint interferometric observing run

*The input mirror of a Herriot delay line is shown in this photo from the early 1980s. The input/output hole can be barely made out at 3 o'clock. This photo was taken at Garching, with Walter Winkler at the left and Karl Maischberger to the right.*

The first joint observation run with interferometric gravitational wave detectors was conducted over the course of 100 hours in 1989 between the Glasgow 10m prototype, situated in Central Scotland, and the Garching 30m prototype, just under 1400 km away in the south of Germany. In the years running up to the observing run, researchers from Glasgow and Cardiff gravitational wave groups had lobbied their UK funding agency, SERC (Science and Engineering Research Council) for money to build a 1 km baseline interferometric detector. There had also at that time been interest expressed by German colleagues towards the BMBF (German Federal Ministry of Education and Research) for a similar project. Eventually, the idea of a joint venture between the UK and Germany was born, with the suggestion from the funding councils being to build prototype facilities to test the concepts proposed for the larger detector as

a first step. One key stipulation from the funding agencies to unlock major funding was that a joint observation run should be demonstrated, ideally within one year. The idea was for the prototypes to be put into observation mode simultaneously, for a period of 100 hours, and for the data to later be analysed by the Cardiff group.

At 15:02 UTC on Thursday 2nd March 1989, the 100 hour run started.

### The interferometers

The prototype interferometers in Glasgow and Garching were similar in that both used laser interferometry to interrogate the changes in separation between mirrors suspended as pendulums; however, the optical layouts were different. The Garching prototype detector was a Michelson interferometer with 30m long arms. The effective length of the arms was multiplied up by having multi-pass delay lines

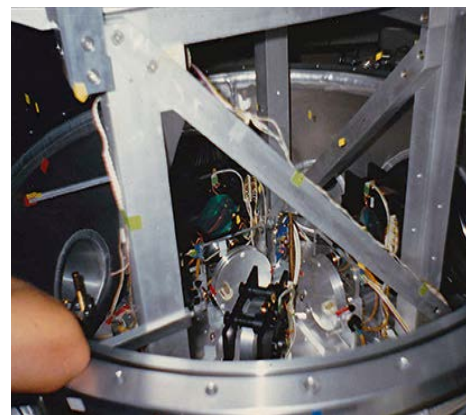

*A view into the vertex chamber of the Garching 30m prototype, with an elbow for scale. The heavy aluminum frame supports the multiple pendulum suspension. One sees the beamsplitter at 45° surrounded by a black plastic (!) frame to carry the OSEMs. The two Pockels cells are mounted in cylindrical disks and suspended as 'optics'. The left ('y') input delay-line mirror is visible with a greenish hue. Convolutions of the bellows coupling to the 'x' 30m arm can be seen to the right. A few yellow tape 'flags' are visible on the suspension fibers as a crude damping mechanism.*

in each arm. The Glasgow prototype had 10m long arms and used resonant Fabry-Perot cavities in the arms to increase their effective length.

Both prototype detectors were normally used as experimental instruments to try to identify and reduce their noise levels. They had little of the automation required for continuous operation and required significant operator input to

signal gave a measure of the differential length changes between the two cavities, and so this included the measure of any gravitational wave signal. A detailed schematic is shown in **Figure 1**.

**Garching 30m prototype**

The Garching prototype was a true Michelson interferometer in its optical layout (shown in **Figure 2** overleaf), with the displacement signal recovered from the antisymmetric port. The laser frequency was stabilized by bringing to interference the return light from the symmetric port with the incoming light, however not through power recycling but rather with a separate beamsplitter. In this way it resembled today's instruments. Differential RF modulation as well as GW-band length feedback was applied after the beamsplitter using inline Pockels cells (so the gravitational wave strain was read out as an error signal from a null servo); a hierarchical servo configuration applied low-frequency forces directly to the mirrors. The Garching group had earlier recognized the need for an input mode cleaner and developed cavities in transmission for this need; however, for this observing run, a single-mode optical fiber was employed that also served to carry the input laser light into the vacuum system.

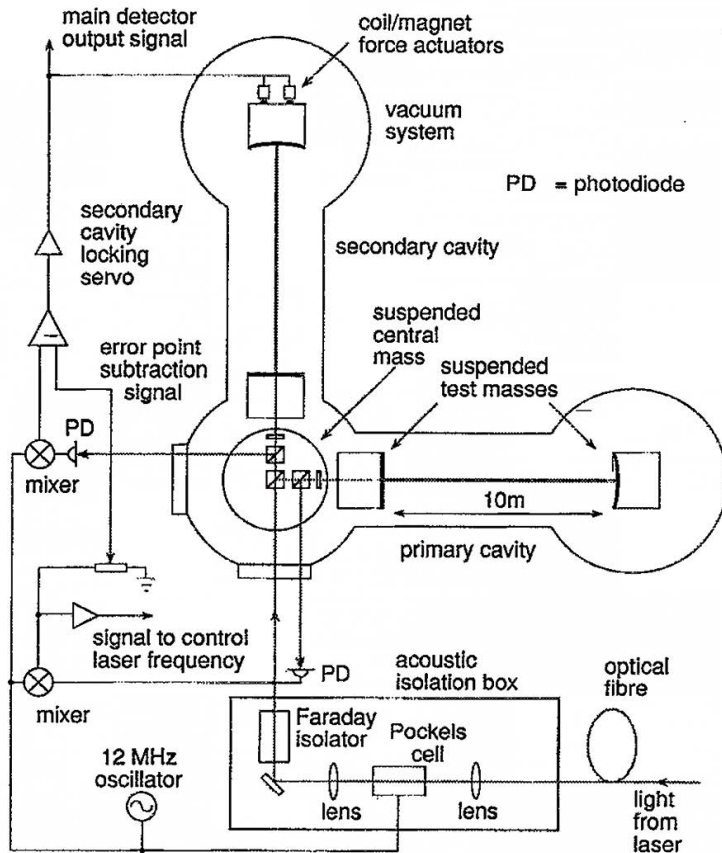

**Figure 1:** Schematic of the Glasgow 10m prototype detector's control systems around the time of the 100 hour run. The laser is not shown in this diagram.

Both prototypes were illuminated by argon-ion lasers operating at 514.5nm (a pretty green colour). These were single frequency, single mode lasers — state of the art at the time — but looking back they were astonishingly inefficient at producing light. They took in around 15kW of electrical power to produce at best 2W of single mode green light, an efficiency of 0.013%. They also produced a lot of hot water; in Glasgow it was planned at one point to use this to help heat the building, but somehow this never materialised!

maintain optimal operation throughout the run.

**The Glasgow 10m prototype**

The resonant arm cavities in the Glasgow prototype required active control. Similar to today's detectors, the input laser frequency was 'locked' to a reference, in this case one of the arm cavities, designated the primary cavity. The second cavity was then driven by electromagnetic actuators to hold it on resonance with the stable laser light. The size of the required feedback

The arm folding was achieved using Herriott delay lines. D. Dewey has a nice description in his thesis (MIT 1986): "A light beam entering the cavity through a hole in the input/output mirror on the central mass bounces back and forth along the interferometer arm many times. Successive reflections occur at a fixed radius from the mirror centers and are equally spaced in angle, forming a Lissajoux pattern of spots. With a judicious choice of the cavity parameters, the beam will exit from the entrance hole after a finite number of passes in the delay line." Because they are not resonant cavities, no



# The 100 hour Glasgow-Garching run

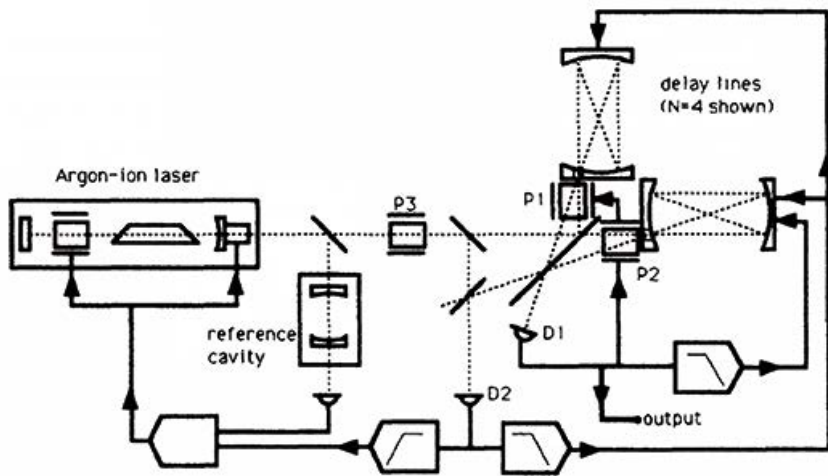

**Figure 2:** Schematic view of the Garching 30m prototype detector's control systems around the time of the 100 hour run. The delay lines in the arms are shown with  $N=4$  single passes of light along the arms. In practice, much larger numbers of passes were used e.g.  $N=90$

'locking' of the length is needed, although scattered light can lead to requirements on the relative mirror motion.

The optics were all suspended by single wire loops, to simplify the mechanical system and maintain high quality factor for the optics. The test masses were suspended as multiple stage pendulums for improved seismic isolation, in perhaps the first application of this approach. The masses were damped locally using the first OSEMs – local optical sensors combined with magnetic motors – similar to those still used in detectors today.

## Data acquisition

Data acquisition systems were employed at both Glasgow and Garching; we describe here only the Glasgow system in detail. The Glasgow system was based on a COMPAQ 386/25MHz computer recording data to an EXABYTE EXB-8200 8mm Cartridge Tape System. Each tape held a staggering 1.4GB of data, and a total of 28 tapes were recorded during the 100 hours. The data was sampled by a single ADC/multiplexer unit: a Cambridge Elec-

tronics Design 1401. Signal conditioning was performed by a set of homemade units that housed a differential amplifier, whitening filter, and Bessel anti-aliasing filters. The complete system is shown in **Figure 3 overleaf**.

The sampling rate was controlled by a Rubidium clock (borrowed from the National Physics Laboratory, in London), which had a stability of 1 part in  $3 \times 10^{11}$  per 100 hours, or about 1 microsecond over the full run. This was well within the requirements for continuous signal searches of 1 part in  $6 \times 10^9$ . Absolute time was taken from the 60kHz MSF signal—a radio signal containing time and frequency standards broadcast by the National Physical Laboratory in the UK and derived from their Caesium clocks. Minute marks were taken from this signal and used to start the data taking. The minute marks were also recorded in one of the digital channels as a reference.

Over the 100 hour run the two instruments acquired data simultaneously during 88% of the experiment, and operated close to their optimum sensitivity simultaneously

for 62% of that time. This was extremely good for prototypes not designed for continuous running. The main limits to the duty cycle in Glasgow, for example, were the thermal sensitivity of the detector, which caused some of the feedback systems to eventually saturate and have to be reset, and the 4 minute gap at the end of each data tape required for rewinding the old tape and inserting a new one.

A comprehensive set of sensitivity and environmental veto signals was recorded for analysis. The total data rate was that of the MSF signal, 60kHz, and this was split between the various channels as shown in **Table 1 overleaf**.

## Data analysis

Using the foundations laid down by Kip Thorne in *300 Years of Gravitation* (1987), and discussions conducted at the first gravitational wave data analysis workshop in Dyffryn House, Cardiff (also 1987), the Cardiff team got to work on searching the data for burst, compact binary, continuous wave and stochastic sources. The results were presented in various PhD theses in the early 1990s and eventually in *Phys Lett A*, 218, 175-180 (1996). The value of the run was well summarized in the article's conclusion, reproduced here 28 years later:

*"Our limits are the first obtained over a broad gravitational wave bandwidth. The false-alarm threshold for a single alarm during the effective coincidence observing period, taking into account the light travel-time between the detectors, and assuming a background of independent Gaussian noise in the detectors, is  $4.5\sigma$ . Given the typical kilohertz burst sensitivity of the detectors, we estimate that our upper bound on  $h$  is only about a factor of roughly 2 worse than the theoretical best limit that these detectors could have set. [...] The real value of our re-*

Rate	Depth	Analog signals
10 kHz	12 bit	Secondary cavity feedback signal – main sensitivity signal below about 3kHz
20 kHz	12 bit	Secondary cavity error point signal – main sensitivity signal above about 3kHz
10 kHz	12 bit	Laser stabilisation error point – intended to show any problems with the laser stabilisation system
10 kHz	8 bit	Microphone signal – summed signal from 3 omnidirectional microphones close to each corner vacuum tank
1.67 kHz	12 bit	Primary cavity visibility signal
1.67 kHz	12 bit	Secondary cavity visibility signal
1.67 kHz	12 bit	Summed signal from 4 seismometers attached to the interferometer's vacuum tanks
1.67 kHz	12 bit	Primary cavity low frequency signal to monitor when the control loop is close to the end of its range
1.67 kHz	12 bit	Oscillation detector – filtered RMS value of the laser frequency stabilisation signal. To detect oscillations in the laser frequency stabilisation that are at many 10s of kHz, and therefore too fast for the normal data acquisition system
1.67 kHz	12 bit	Battery – a DC signal to saturate an ADC – recorded as a check that the multiplexer hadn't slipped a channel
		<b>Digital signals</b>
10 kHz	1 bit	Minute mark from the MSF timing system
10 kHz	1 bit	Calibration – ON when a calibration signal is being applied
10 kHz	1 bit	Mains frequency – 50Hz mains frequency, hopefully to track the exact frequency to aid subtraction of contamination in post-processing
10 kHz	1 bit	Alarm – a big red button the operators could press when they were unhappy about something
10 kHz	1 bit	Multiplexer synchronisation – recorded as a check that the multiplexer hadn't slipped a channel

▲  
**Table 1:** Complete list of data and veto signals recorded by the Glasgow 10m prototype detector.  
 ▼

sults is a test of interferometric observing. Our results are very encouraging for large-scale interferometers, since they indicate that attention to detector control and non-Gaussian noise could raise the sensitivity and duty cycle of working detectors very close to their optimum performance.”

LIGO<sub>2017</sub>

**References**

History: Data Analysis for 100 Hour Run, talk presented at Beyond GEO-HF Meeting, Mallorca, 2016, Bernard F. Schutz

Results of the first coincident observations by two laser-interferometric gravitational wave detectors. Phys Lett A, 218, 175-180 (1996).

Investigations and developments relevant to a Prototype Interferometric Gravitational Wave detector, 1990, PhD Thesis, David I Robertson

The Glasgow 10m prototype laser interferometric gravitational wave detector; D. I. Robertson, E. Morrison, J. Hough, S. Killbourn, B. J. Meers, G. P. Newton, N. A. Robertson, K. A. Strain, and H. Ward. Review of Scientific Instruments 66, 4447 (1995).

Gravitational Wave Detection by Interferometry (Ground and Space); Sheila Rowan and Jim Hough. Living Reviews in Relativity (2000).

Noise behavior of the Garching 30-meter prototype gravitational-wave detector; D. Shoemaker, R. Schilling, L. Schnupp, W. Winkler, K. Matischberger, and A. Rüdiger. Phys Rev D (1988).

D. Herriott, H. Kogelnik, and R. Kompfner. Appl. Opt. 3, 523 (1964).

▼  
**Figure 3:** Schematic of the Glasgow data taking system.

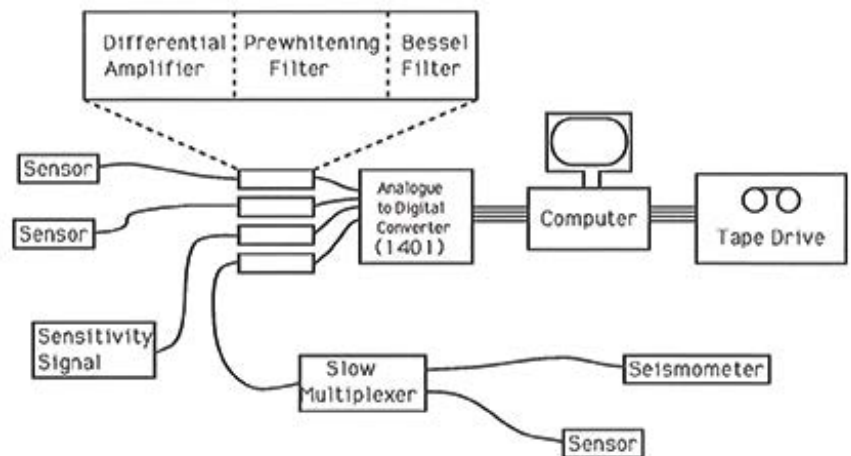



# Remembering Ron Drever

26 October 1931 –  
7 March 2017



Drever was co-founder of LIGO, along with Kip S. Thorne and Rainer Weiss. “Ron was one of the most inventive scientists I’ve known, and his contributions to LIGO were huge,” says Thorne. “His approach to physics was so different from mine: intuitive rather than analytic. He could see things intuitively, quickly, that would take hours for me to understand in my more mundane way with mathematical calculations.”

In 1970, Drever and a young colleague, James Hough, created a research group at Glasgow University working on gravitational-wave detection. Their group built a clever variant of the bar detectors invented by Joseph Weber of the University of Maryland. The bar experiments proved unsuccessful, and in 1973, Drever’s group began building in Glasgow a prototype gravitational-wave interferometer of the sort first envisioned by LIGO co-founder Weiss but with significant changes devised by Drever. In 1979, Caltech recruited Drever to initiate a research group in gravitational-wave experiments which in 1984 teamed up with Weiss’s group at MIT and Thorne’s Caltech theory group to create LIGO.

Drever made several major contributions to the design of LIGO. He modified the way the light was trapped between the mirrors of each LIGO arm: trapping it resonantly, so that the arm functioned as a so-called Fabry-Pérot cavity, an improvement on Weiss’s original way of trapping the light with hundreds of discrete bounces on the mirrors. He invented a way to recycle unused light back into the interferometer and a way to tune the interferometer to detect gravitational waves with different characteristics—those with very constant frequencies or those with rapidly changing frequencies, for example.

Relying on earlier ideas of Robert Pound at Harvard, Drever invented a method to make the laser light highly stable in frequency and perfected it in collaboration with John Hall at the University of Colorado. This method, now called Pound-Drever-Hall laser stabilization, has come to be used widely in other areas of science and

technology. These various inventions were tested in prototype interferometers that were built at Caltech and in Glasgow under Drever’s leadership, and variants of them are now incorporated into LIGO.

Drever passed away after a rapid deterioration in his health. From a statement from his family: “Ronald dedicated his lifetime to researching gravitational wave detection through LIGO and despite the fact dementia featured in his latter years, he was still aware of the global recognition that he and his colleagues ... had achieved”. He was “unique and unconventional but very caring with a strong sense of humour”.

In addition to the 2016 Kavli Prize in Astrophysics, the Shaw Prize in Astronomy, the Gruber Prize in Cosmology, and the Special Breakthrough Prize in Fundamental Physics, all earned with Thorne and Weiss, Drever was awarded the American Physical Society’s 2007 Einstein Prize with Weiss.

“I spent a wonderful hour talking with Ron last September in Edinburgh after receiving our Kavli Prize,” says Thorne. “He was remarkably clear-headed, reminisced with me about our years working together on LIGO, and expressed pleasure in LIGO’s success.”

# Remembering Neil Gehrels

3 October 1952 –  
6 February 2017



▲  
Neil Gehrels at Astrophysics Science Division  
Peer Awards, July 2013

Neil Gehrels passed away suddenly on February 6, 2017, of pancreatic cancer. Neil was an acknowledged leader in the field of gamma-ray astronomy, having served as Project Scientist for Compton Gamma-ray Observatory and as Principal Investigator for Swift. He also won many awards and was widely recognized for his scientific accomplishments. Several formal obituaries have been written about his illustrious career, including by the American Astronomical Society (AAS) [1] where he was a past chair of the High Energy Astrophysics Division, and by Caltech [2] where he was a distinguished alumnus.

However, I also remember Neil's strong commitments to education, public outreach, and diversity in astrophysics, including in particular within the gravitational-wave community. At the time of his passing, Neil was continuing to serve the LIGO Scientific Collaboration as one of the two co-chairs of the Diversity working

group. In this role, Neil actively participated in organizing diversity events, as well as reaching out to speakers for participation in LVC meetings. Neil was also extremely committed to Education and Public Outreach (E/PO). His enthusiastic support of NASA's Swift and Fermi's E/PO programs, provided funding beyond what was required by NASA, enabling me to thrive in a career doing E/PO that now supports many of LIGO's outreach efforts.

Neil's commitment to diversity in Physics and Astronomy was strong and deep. His wife Ellen Williams is a Distinguished University Professor at the University of Maryland and former Director of ARPA-E at DOD. Together they raised two children, Thomas, an electrical engineer; and Emily, a graduate student in Applied Physics. These personal experiences inspired Neil to write several articles for the AAS Committee on the

Status of Women in Astronomy, discussing "Strategies for Combining Career and Family" [3] and "Future Directions in the Work-Family Equation" [4]. He also had a great interest in history, leading to articles such as "First Woman Astronomer Hypatia: Paying Dearly for her Beliefs" [5]. Articles like these illustrate the depth of his commitment to diversity and education issues. Neil and his family volunteered in disadvantaged communities around Goddard, and in 2005 he helped develop an internship program for local high school students with hardships to work in his labs.

Peter Meszaros notes in the AAS obituary that, after Neil won a competitive NASA mission proposal, "he always reached out to the other competitors to offer collaborations. He never viewed the competition as a personal contest but as a means to achieve the best science."

Neil's "non-scientific" contributions to our community will continue to live on through his thoughtful words and a lifetime of support and action on behalf of all of us.

[1] AAS <https://aas.org/obituaries/neil-gehrels-1952-2017?page=1>

[2] Caltech <http://www.caltech.edu/news/neil-gehrels-phd-82-1952-2017-54103>

[3] <http://womeninastronomy.blogspot.com/2015/08/strategies-for-combining-family-and.html>

[4] <http://womeninastronomy.blogspot.com/2015/02/future-directions-in-work-family.html>

[5] [http://womeninastronomy.blogspot.com/2013/04/hypatia\\_15.html](http://womeninastronomy.blogspot.com/2013/04/hypatia_15.html)



## Comment: Searching for a faculty job



Thomas Dent

in the less brain-freeze the questions in that panel interview are likely to cause.

I am going to outright contradict Conor on one point - "You won't be offered a job if people don't know who you are." There are going to be open positions at places without an established GW group. The people on the hiring panel may never have thought about (say) sloshing cavities or Bayesian wavelet analysis and there's no reason they have to have heard of you: so you need to be able to explain in a few minutes, non-technically, why what you do is important and how that's going to evolve in the future. (That sounds a bit like... outreach?)

Finally, as Conor hinted, there is an awful lot more to being a faculty member than excellent research. Teaching, funding applications, administration, advising and mentoring students and postdocs, "impact"... a university asks a lot of its faculty and you need to respond to these aspects of the job too.

LIGO<sub>2017</sub>

*Editor's note: As Tom points out, experiences with the job market can vary tremendously, and we plan to revisit stories of academic and non-academic career paths in future issues.*

*Thomas Dent is currently a senior scientist at AEI Hannover, having joined LIGO in 2009 via Cardiff University after (n-2) previous jobs in particle physics and cosmology. When not worrying about false alarms in GW searches, his favourite distraction is to cycle up and down absurdly steep hills and eat absurdly large meals, preferably in Italy.*

Conor's article "How to get a faculty position?" in the last LIGO magazine was a nice pep talk to promote your research: travel, talk to people, listen to what's going on around you .. that's what you should do in science anyway! But from personal experience, I would hesitate to call it a guide to applying for faculty jobs. I can't pretend to be an expert, but here's a few things people might need to know.

The turnover of postdocs in gravitational-wave research is much, much larger than the number of permanent jobs at research universities. You might see similar numbers of postdocs and faculty at meetings, but that's because faculty stick around for decades while postdocs are only visible for a few years. So, even if you're the best in the world at the research you do, you probably won't get the first job you apply to. You might not even get onto the shortlist. Institutions will be looking for many different things in an applicant and unless you're very lucky you won't be top of the list in all the things they are looking for. So plan for success, but also plan for failure, and plan to apply again. The more applications you put

## General

The Royal Society Summer Science Exhibition this July included an exhibit on gravitational waves entitled, "Listening to Einstein's Universe" by UK and German universities in the LSC. The exhibit included informative backdrops, videos, LISA models, handouts, scientists on hand to answer questions, and interactive elements such as a rubber universe, mirror pendulum, interferometer, apps, and games.

The Gravitational Physics Division has been newly created within The European Physical Society. This division represents and provides a forum for European scientists interested in any aspect of gravitational physics.

The Max Planck Institute for Gravitational Physics (AEI) has expanded through the addition of a new research team. Led by Dr. Frank Ohme, the Max Planck Independent Research Group "Binary Merger Observations and Numerical Relativity" will study collisions of black holes and neutron stars through sophisticated computer simulations, exploring some of the fundamental questions in the new field of gravitational-wave astronomy over the next five years.

In a meeting on 20 June 2017, ESA's Science Programme Committee selected the space-based gravitational-wave detector "Laser Interferometer Space Antenna" (LISA) for ESA's third large (L3) mission in the "Cosmic Vision" plan. After this selection, the design and costing of the mission will now be completed. It will then be proposed for "adoption" by ESA, followed by the construction of the spacecraft. The launch of the mission is expected in 2034.

## Career Updates

**Giacomo Ciani**, formerly an Assistant Scientist at the University of Florida, became a fixed term researcher at the University of Padova while continuing work at the University of Florida. Starting in September he will be moving to the University of Padova and transitioning from the LSC to the Virgo collaboration.

**Hunter Gabbard**, a Fulbright Fellow at AEI Hannover, is moving to the University of Glasgow where he was awarded the Scottish Universities Physics Alliance (SUPA) prize for Ph.D. study.

**Amber Stuver** at LIGO Livingston and Louisiana State University will become an Assistant Professor of Physics at Villanova University this fall. She plans to apply for LSC membership and continue her work in the Burst and EPO groups.

**Jade Powell** graduated with a PhD from the University of Glasgow and will begin at the Swinburne University of Technology as an OzGrav postdoc.

**Simon Stevenson** graduated with a PhD from the University of Birmingham and will begin at the Swinburne University of Technology as an OzGrav postdoc.

**Marissa Walker** defended her PhD thesis on "The Effects of Instrumental Noise on Searches for Generic Transient Gravitational Waves in Advanced LIGO" in April 2017, and is now a postdoc at California State University in Fullerton.

**Guillermo Valdes** defended his PhD thesis on "Data Analysis Techniques for LIGO Detector Characterization" in July 2017, and is now a postdoc at Louisiana State University.

**Sheila Dwyer** has accepted a permanent scientist position at LIGO Hanford.

**Nutsinee Kijbunchoo** from LIGO Hanford moved to the Australian National University to begin Ph.D. study.

**Hsin-Yu Chen** received her PhD from the University of Chicago, and will begin a postdoc position at Harvard.

**Ben Farr**, a McCormick Fellow at the University of Chicago, will be starting a faculty position at the University of Oregon in the Fall.

**Karl Wette**, formerly from AEI Hannover, took a Research Fellow position at the Australian National University, as part of the new ARC Centre of Excellence for Gravitational Wave Discovery (OzGrav).

**Varun Bhalariao**, formerly a postdoc at IUCAA in Pune, is now an assistant professor in the Department of Physics at the Indian Institute of Technology Bombay.

**Antonios Kontos**, a postdoc at the MIT LIGO Lab, will become an Assistant Professor in Physics at Bard College this fall where he will continue research in Optical Physics, Precision Measurements and LIGO.

**Vivien Raymond** will be moving from the Max Planck Institute in Potsdam to join the Physics and Astronomy faculty at Cardiff University in January 2018.

## Awards

Three representatives of the team that developed the second-generation detectors for the Laser Interferometer Gravitational-Wave Observatory (LIGO) and used them to detect oscillations in the fabric of space-time will share the **2018 Lancelot M. Berkeley - New**



## **York Community Trust Prize for Meritorious Work in Astronomy.**

## **The 2017 Royal Astronomical Society Group Achievement Award in Astronomy**

is given to the Laser Interferometer Gravitational-Wave Observatory (LIGO) team. Martin Hendry, Mike Cruise and Francesco Pannarale received the award on behalf of the LSC.

**Lynn Cominsky** at Sonoma State received the Frank J. Malina Astronautics Medal from the International Astronautical Federation. The award will be handed to her at the International Astronautical Conference in Adelaide Australia on 9/29/17.

**Cody Messick** was awarded the Academic Computing Fellowship for his graduate work at Penn State.

**Professor K G Arun** at The Chennai Mathematical Institute, Siruseri received the N R Sen Young Researcher Award from the Indian Association for General Relativity and Gravitation (IAGRG) in 2017.

The 2016 GWIC Thesis Prize is awarded to **Eric Oelker** for his thesis "Squeezed States for Advanced Gravitational Wave Detectors" at MIT. His thesis describes a beautiful experiment demonstrating frequency-dependent squeezed states suitable for Advanced LIGO. This is a key element in all the designs for detectors with sensitivity beyond the second generation baselines.

The 2016 Stefano Braccini Thesis Prize is awarded to **Davide Gerosa** for his thesis "Source modelling at the dawn of gravitational-wave astronomy" at the University of Cambridge. Dr. Gerosa's thesis includes a wide variety of topics relevant to gravitational waves, as well as other topics in astrophysics: astrophysical explorations of accretion disks, analytically challenging work in mathematical relativity and post-Newtonian theory, and nu-

merical relativity coding of supernova core-collapse in relativity and modified gravity.

**The University of Glasgow** is celebrating its success in the 2017 Herald Higher Education Awards in Scotland. The Glasgow Science Festival team received the "Outstanding Contribution to the Local Community" award for "Chasing the Waves" – a comedy musical about the detection of gravitational waves that was written in collaboration with members of the Institute for Gravitational Research. You can find out more about Chasing the Waves at <http://www.gla.ac.uk/events/sciencefestival/eventsandprojects/projects/chasingthewaves/>.

**Maya Fishbach**, a student at the University of Chicago, received an NSF Graduate Research Fellowship.

**Professor Susan Scott** at ANU was selected to join an international team of 80 women for the Homeward Bound 2018 program. This 12 month leadership program is an initiative, turned global movement, which aims to heighten the impact of women with a science background in order to influence policy and decision making as it shapes our planet over the next decade. It culminates in a 3 week female expedition to Antarctica in February-March 2018. She would like to encourage women in the LVC, from all countries and positions, to consider applying for the program in future years as this is a 10 year initiative.

**Tim Dietrich**, now a postdoctoral scholar at AEI Potsdam, received both the Ph.D. thesis award of the German Physical Society and the thesis prize of Friedrich Schiller University in Jena for his Ph.D. thesis on gravitational wave signals of merging neutron stars obtained from Jena University.

**Professor Karsten Danzmann**, director at the Max Planck Institute for Gravitational Physics (AEI) in Hannover, Germany, and di-

rector of the Institute for Gravitational Physics at Leibniz Universität Hannover receives The Körber European Science Prize for the development of key technologies for gravitational-wave detection.

**Professor Karsten Danzmann**, director at the Max Planck Institute for Gravitational Physics (AEI) in Hannover and director of the Institut für Gravitationsphysik of Leibniz Universität Hannover, will receive the Otto Hahn Prize for his pioneering research for the direct detection of gravitational waves.

**Gabriela Gonzalez** was elected to the National Academy of Sciences.

**Nergis Mavalvala** was elected to the National Academy of Sciences.

**Rainer Weiss, Kip S. Thorne, Barry C. Barish, and LIGO Scientific Collaboration** have been bestowed with the 2017 Princess of Asturias Award for Technical and Scientific Research.

**Professor Alicia M Sintes** from the Balearic Islands University was awarded the Ramon Llull Prize 2017 by the Govern de les Illes Balears for her research work on gravitational waves and career in academia.

On March 18, 2016, **Neil Cornish and his team** at Montana State University received a letter of congratulations from the Governor of Montana.

For her work on LIGO data analysis, **Holly Gummelt** of University of Washington Bothell was awarded the UWB Founders' Fellowship, which recognizes and supports undergraduates involved in research.

**Valerio Boschi** from the University of Pisa and **Andreas Freise** from the University of Birmingham received the 2017 Cristina Torres Memorial Outreach Awards.

## New LSC Positions

Collaboration members who have taken on new leadership positions in the LSC organization:

**Peter Shawhan** is DAC Chair as of March 2017.

**Jess McIver** is DetChar co-Chair as of March 2017.

**Jolien Creighton** is CBC co-Chair.

**Evan Goetz** is CW co-Chair.

**Letizia Sammut** and **Andrew Matas** are Stochastic co-Chairs.

**Erik Katsavounidis** is EM Liaison as of March 2017.

**Martin Hendry** is EPO Chair.

**Amber Stuver** is Informal Education/Public Outreach lead as of March 2017.

**Jocelyn Read** is Magazine Chair.

**Ray Frey** is Chair of the Diversity Committee as of March 2017.

**Josh Smith** is co-Chair of the Speakers Board as of March 2017.

**Peter Saulson** is Ombudsperson as of March 2017.

**Patrick Sutton** is LVC Meeting Chair as of March 2017.

**David Shoemaker** is Spokesperson as of March 2017.

**Laura Cadonati** is Deputy Spokesperson as of March 2017.

LIGO is funded by the National Science Foundation and operated by the California Institute of Technology and Massachusetts Institute of Technology. This material is based upon work supported, in part, by the National Science Foundation. Any opinions, findings, and conclusions or recommendations expressed in this material are those of the author(s) and do not necessarily reflect the views of the National Science Foundation.

The authors gratefully acknowledge the support of the United States National Science Foundation (NSF) for the construction and operation of the LIGO Laboratory and Advanced LIGO as well as the Science and Technology Facilities Council (STFC) of the United Kingdom, the Max-Planck-Society (MPS), and the State of Niedersachsen/Germany for support of the construction of Advanced LIGO and construction and operation of the GEO600 detector. Additional support for Advanced LIGO was provided by the Australian Research Council. The authors also gratefully acknowledge the support of LSC related research by these agencies as well as by the Council of Scientific and Industrial Research of India, Department of Science and Technology, India, Science & Engineering Research Board (SERB), India, Ministry of Human Resource Development, India, the Istituto Nazionale di Fisica Nucleare of Italy, the Spanish Ministerio de Economía y Competitividad, the Conselleria d'Economia i Competitivitat and Conselleria d'Educació, Cultura i Universitats of the Govern de les Illes Balears, the European Union, the Royal Society, the Scottish Funding Council, the Scottish Universities Physics Alliance, the Hungarian Scientific Research Fund (OTKA), the National Research Foundation of Korea, Industry Canada and the Province of Ontario through the Ministry of Economic Development and Innovation, the Natural Science and Engineering Research Council Canada, Canadian Institute for Advanced Research, the Brazilian Ministry of Science, Technology, and Innovation, Fundação de Amparo à Pesquisa do Estado de São Paulo (FAPESP), Russian Foundation for Basic Research, the Leverhulme Trust, the Research Corporation, Ministry of Science and Technology (MOST), Taiwan and the Kavli Foundation.

Online ISSN: 2169-4443

World Wide Web URL: <http://www.ligo.org/magazine>

Publisher: LIGO Scientific Collaboration, Pasadena, CA, USA

LIGO DCC: LIGO-P1700041

Contact: [magazine@ligo.org](mailto:magazine@ligo.org)

**Editor-in-Chief:** Jocelyn Read

**Deputy Editor-in-Chief:** Hannah Middleton

**Editors:** Laura Cadonati, Alex DeMaio, Andreas Freise, Tobin Fricke, Gabriela González, Amber Strunk Henry, Dale Ingram, Nutsinee Kijbunchoo, Mike Landry, Sean Leavey, Susanne Milde, Brian O'Reilly, Sascha Rieger, Lucía Santamaría, Brett Shapiro

**Design & production:** Milde Marketing | Science Communication + formgeber

Printed by GS Druck und Medien GmbH Potsdam



# HOW DID YOU SPEND YOUR BREAKTHROUGH PRIZE MONEY?

## RICH SENIOR SCIENTISTS

"FUNDED A GRADUATE STUDENT FELLOWSHIP"  
-RAE WEISS

"FUNDED STUDENT TRAVELS."  
-FRED RAAB  
-STAN WHITCOMB  
-RICCARDO DEALVO



## BACK TO LIGO

"FUNDED MYSELF TO GO TO GWADW."  
-JEFF KISSEL

"SPENT IT ON LIGO VOYAGER R&D."  
-OYUNO AGUIAR



## POOR GRADUATE STUDENTS

"CATCHING UP ON STUDENT LOANS."  
-ALEX URBAN

"PAID TUITION."  
-HEATHER FONG



## MISC.

"A PIANO FOR OUR 8 YRS OLD SO THAT SHE CAN PLAY THE SYMPHONY OF THE UNIVERSE!"  
-ALICIA & SASCHA



"LARG GRIZZLY 45WM PISTOL."  
-PHIL EHRENS



"A FAMILY TRIP TO DISNEY. THEY EARNED IT."  
-TYSON LITTENBERG



"SAVINGS."  
-GRANT MEADORS



"A TRIP TO HARRY POTTER WORLD AND GALAPAGOS ISLANDS."  
-LAURA NUTTALL



"I BOUGHT A SMALL FISHING BOAT."  
-CALM TORRIE



"IVF TREATMENT. IT WAS A SUCCESS! WE ARE EXPECTING A LITTLE GIRL IN OCTOBER."  
-ANONYMOUS

